

AIRTRONIC / AIRTRONIC M

Technical description, installation,
operation and maintenance instructions.



Airtronic

Order no.

Airtronic D2, 12 V

25 2069 05 00 00

Airtronic D2, 24 V

25 2070 05 00 00

Complete Airtronic D2 package

12 V with mini controller

25 2115 05 00 00

12 V with EasyStart Select

25 2675 05 00 00

24 V with mini controller

25 2116 05 00 00

24 V with EasyStart Select

25 2676 05 00 00

Airtronic M

Order no.

Airtronic B3 Plus, 12 V

20 1944 05 00 00

Airtronic B4, 12 V

20 1812 05 00 00

Airtronic D3, 12 V

25 2317 05 00 00

Airtronic D4, 12 V

25 2113 05 00 00

Airtronic D4, 24 V

25 2114 05 00 00

Airtronic D4 Plus, 12 V

25 2484 05 00 00

Airtronic D4 Plus, 24 V

25 2498 05 00 00

**Air heater for diesel and petrol
operating independently of the engine.**



Eberspächer

A world of comfort

1 Introduction

Contents

Chapter	Title	Contents	Page
1	Introduction	<ul style="list-style-type: none"> • Contents2 • Concept of this manual.....3 • Special text structure, presentation and picture symbols.....4 • Important information before starting work.....4 • Statutory regulations.....5, 6 • Safety instructions for installation and operation.....7 • Accident prevention.....7 	
2	Product information	<ul style="list-style-type: none"> • Scope of supply: heater, universal installation kit and complete packages8, 9 • Scope of supply: heater and “Plus” installation kit10, 11 • Technical data Airtronic D212 • Technical data Airtronic D3, D4, D4 Plus13 • Technical data Airtronic B3 Plus, B414 • Main dimensions.....15 	
3	Installation	<ul style="list-style-type: none"> • Installation and location16 • Installation location16, 17 • Possible installation positions.....18 • Cable harness connection, right or left.....18 • Mounting and fastening19 • Nameplate.....20 • Heater air system21 • Exhaust system22 • Combustion air system.....23 • Fuel supply24 – 28 	
4	Operation and function	<ul style="list-style-type: none"> • Operating instructions / important information for operation.....29 • Initial commissioning.....29 • Description of functions30 • Control and safety devices / EMERGENCY OFF31 	
5	Electrical system	<ul style="list-style-type: none"> • Heater wiring32 • Parts list for the circuit diagrams / Circuit diagrams33 – 40 	
6	Troubleshooting Maintenance Service	<ul style="list-style-type: none"> • In case of faults, please check the following points41 • Troubleshooting41 • Maintenance instructions.....41 • Service41 	
7	Environment	<ul style="list-style-type: none"> • Certification42 • Disposal42 • EU Declaration of Conformity.....42 	
8	Lists	<ul style="list-style-type: none"> • List of key words43, 44 • List of abbreviations.....44 	



1 Introduction

Concept of this manual

This manual aims to support the service company installing the heater and to provide the user with all important information about the heater. The manual has been divided into 8 chapters to make it easier to find the corresponding information quickly.

1

Introduction

Here you will find important introductory information about installation of the heater and about the structure of the manual.

2

Product information

Here you will find information about the scope of supply, the technical data and the dimensions of the heater.

3

Installation

Here you will find important information and instructions referring to installation of the heater.

4

Operation and function

Here you will find information about the operation and function of the heater.

5

Electric system

Here you will find information about the electronic system and electronic components of the heater.

6

Troubleshooting / maintenance / service

This section contains information on possible faults and malfunctions, troubleshooting, maintenance and the service hotline.

7

Environment

Here you will find information about certification and disposal of the heater together with the EU Declaration of Conformity.

8

Lists

Here you will find the key word list and abbreviations list.

1 Introduction

Special text structure, presentation and picture symbols

This manual uses special text structures and picture symbols to emphasise different contents. Please refer to the examples below for the corresponding meanings and associated actions.

Special structure and presentations

A dot (•) indicates a list which is started by a heading. If an indented dash (–) follows a dot, this list is subordinate to the dot.

Picture symbols



Regulation!

This picture symbol with the remark "Regulation" refers to a statutory regulation. Failure to comply with this regulation results in expiry of the type permit for the heater and preclusion of any guarantee and liability claims on Eberspächer Climate Control Systems GmbH & Co. KG. and its associated companies.



Danger!

This picture symbol with the remark "Danger!" refers to the risk of a fatal danger to life and limb. Under certain circumstances, failure to comply with these instructions can result in severe or life-threatening injuries.



Caution!

This picture symbol with the remark "Caution!" refers to a dangerous situation for a person and / or the product.

Failure to comply with these instructions can result in injuries to people and / or damage to machinery.

Please note!

These remarks contain application recommendations and useful tips for installation of the heater.

Important information before starting work

Range of application of the heater

The air heater operating independently of an engine is intended for installation in the following vehicles, depending on its heating output:

- All types of vehicles (max. 8 seats + driver's seat) and their trailers
- Construction machinery
- Agricultural machinery
- Boats, ships and yachts (only diesel heaters)
- Camper vans

Please note!

- The heaters (only diesel heaters, 24 volt) can be installed in vehicles used for the transport of dangerous goods as per ADR.
- The current controller is to be replaced by a special controller when the heater is to be used to heat the freight compartment / cargo (order no. see heater price list or spare parts list).
- The „Plus“ installation kits are intended for installation in a camper van.

Purpose of the heater

- Pre-heating, de-misting windows
- Heating and keeping the following warm:
 - Driver and working cabs, Ship's cabins
 - Freight compartments
 - Passenger and crew compartments
 - Camper vans

On account of its functional purpose, the heater is **not** permitted for the following applications:

- Long-term continuous operation, e.g. for preheating and heating of:
 - Residential rooms
 - Garages
 - Work huts, weekend homes and hunting huts
 - Houseboats, etc.
- Heating or drying:
 - Living creatures (people or animals) by blowing hot air directly at the subject
 - Objects
 - Blowing hot air into containers



Caution!

Safety instructions for application and proper purpose

- The heater must only be used and operated for the range of application stated by the manufacturer in compliance with the "Operating instructions" included with every heater.



1 Introduction

Statutory regulations

The Federal Motor Transport Authority has issued an "EC type approval", "EMC type-approval" and the approval for a component according to ECE R122 and ECE-R10 for the heater for installation in motor vehicles with the following official type-approval marks, noted on the heater name plate.

Type-approval marks

	Airtronic	Airtronic M
EG	00 0025	00 0026
EMV	03 1516	03 1653
ECE	122R-000025 10R-031516	122R-000026 10R-031653



Regulations!

Extract from Directive 2001 / 56 / EC Annex VII and ECE Regulation No. 122 of the European Parliament and of the Council

General regulations

• Operating state display

- A clearly visible operating display in the user's field of vision must indicate when the heater is switched on and off.

Regulations concerning installation in the vehicle

• Scope

- Subject to differing stipulations in the following section, combustion heaters must be installed according to the provisions of Annex VII.
- It is assumed that Class O vehicles with heaters for liquid fuel conform to the provisions of the directive.

• Arrangement of the heater

- Parts of the structure and other components near the heater must be protected from excessive heat exposure and possible fuel or oil contamination.
- The heater must not pose a fire hazard even when it overheats. This requirement is deemed to be fulfilled if adequate clearance is ensured for all parts during installation, sufficient ventilation is provided and fireproof materials or heat shields are used.
- The heater must not be mounted in the passenger compartment of vehicles in class M₂ and M₃. However, a heater in a hermetically sealed enclosure which also complies with the aforementioned conditions may be used.
- The factory nameplate or duplicate must be affixed so that it can still be easily read when the heater is installed in the vehicle.

- All appropriate precautions must be taken when arranging the heater to minimise the risk of injuries to persons or damage to other property.

• Fuel supply

- The fuel intake connection must not be located in the passenger compartment and must be sealed with a properly closing lid to prevent any fuel leaks.
- In heaters for liquid fuel where the heater fuel is separate from the vehicle fuel, the type of fuel and intake connection must be clearly identified.
- A warning sign is to be fixed to the intake connection indicating that the heater must be switched off before refuelling.

• Exhaust system

- The exhaust outlet must be arranged so as to prevent any penetration of exhaust fumes into the vehicle interior through the ventilation system, warm air intakes or open windows.

• Combustion air intake

- The air for the heater's combustion chamber must not be sucked in from the vehicle's passenger compartment.
- The air intake must be arranged or protected in such a way that it cannot be blocked by other objects.

• Hot air intake

- The heater's air supply must consist of fresh air or circulated air and must be sucked in from a clean area, which cannot be contaminated by exhaust fumes from the engine, the combustion heater or any other source in the vehicle.

- The intake pipe must be protected by a grid or other suitable means.

• Hot air outlet

- The hot air pipes within the vehicle must be arranged or protected in such a way that there is no risk of injury or damage if they are touched.
- The air outlet must be arranged or protected in such a way that it cannot be blocked by any objects.

• Automatic control of the heating system

- If the engine fails, the heating system must be automatically switched off and the fuel supply stopped within 5 seconds. The heater may remain in operation if a manual device has already been activated.

1 Introduction

§ Statutory Regulations!

Additional regulations for certain vehicles named in Directive 94 / 55 / EC of the ADR Agreement

Scope

This appendix applies to vehicles for which the special provisions of Directive 94 / 55 / EC apply to combustion heaters and their installation.

Definition of terms used

The vehicle designations "EX / II", "EX / III", "AT", "FL" and "OX" according to Chapter 9.1 of the ADR Agreement Directive 94 / 55 / EC are used for the purposes of this annex.

Technical regulations

General provisions (EX / II, EX / III, AT, FL and OX vehicles)

Avoid heating and ignition

Combustion heaters and their exhaust pipes must be designed, arranged, protected or covered so that any unacceptable risk of heating or ignition of the load is avoided. This regulation is deemed to be complied with if the fuel tank and the exhaust system of the unit conform to the regulations described in the "Fuel tank" and "Exhaust system and exhaust pipe layout" paragraphs. The complete vehicle must be checked for compliance with these regulations.

Fuel tanks

Fuel tanks for supplying the heater shall conform to the following regulations:

- In the event of any leakage, the fuel shall drain to the ground without coming into contact with hot parts of the vehicle or the load;
- fuel tanks containing petrol shall be equipped with an effective flame trap at the filler opening or with a closure enabling the opening to be kept hermetically sealed.

Exhaust system and exhaust pipe layout

The exhaust system as well as the exhaust pipes shall laid out or protected to avoid any danger to the load through heating or ignition. Parts of the exhaust system situated directly below the fuel tank (diesel) shall have a clearance of at least 100 mm or be protected by a thermal shield.

Switching on the combustion heater

The combustion heater may only be switched on manually. Automatic switching on via a programmable switch is not permitted.

EX / II and EX / III vehicles

Combustion heaters for gaseous fuels are not permitted.

FL vehicles

Combustion heaters must be able to be taken out of service/disabled at least by the methods described in the following:

- a) Switching off manually in the driver's cabin
- b) Switching off the vehicle's engine; in this case the heater may be manually switched back on by the vehicle driver;
- c) Starting up of a feed pump installed in the vehicle for the dangerous goods carried.

Combustion heater after-run

After-running of the switched off combustion heater is permitted. In the cases named in the „FL vehicles“ paragraph under letters b) and c) the supply of combustion air must be interrupted by suitable means after a maximum after-run period of 40 seconds. Only combustion heaters whose heat exchangers are verifiably not damaged by the reduced after-run period of 40 seconds beyond their usual use period may be used.

Please note!

- Compliance with the statutory regulations, the additional regulations and safety instructions is prerequisite for guarantee and liability claims. Failure to comply with the statutory regulations and safety instructions and incorrect repairs even when using original spare parts make the guarantee null and void and preclude any liability for Eberspächer Climate Control Systems GmbH & Co. KG.
- Subsequent installation of this heater must comply with these installation instructions.
- The statutory regulations are binding and must also be observed in countries which do not have any special regulations.
- When the heater is to be installed in vehicles not subject to the German Ordinance for the Registration of Motor Vehicles (StVZO), for example ships, the specially valid regulations and installation instructions for these special applications must be observed.
- Installation of the heater in special vehicles must comply with the regulations applying to such vehicles
- Other installation requirements are contained in the corresponding sections of this manual.



1 Introduction

Safety instructions for installation and operation



Danger!

Risk of injury, fire and poisoning!

- The heater must only be started up when the maintenance flap is closed and the outlet hood is mounted in position.
 - The maintenance flap must not be opened during operation.
 - Disconnect the vehicle battery before commencing any kind of work.
 - Before working on the heater, switch the heater off and let all hot parts cool down.
 - The heater must not be operated in closed rooms, e.g. in the garage or in a multi-storey car park.
 - Adjustable hot air outlets must always be adjusted so that they cannot blow hot air directly at living creatures (people, animals) or objects sensitive to temperature (loose and / or fastened).
- The following measures are not allowed:
 - Changes to components relevant to the heater.
 - Use of third-party components not approved by Eberspächer.
 - Nonconformities in installation or operation from the statutory regulations, safety instructions or specifications relevant to safe operation as stated in the installation instructions and operating instructions. This applies in particular to the electrical wiring, fuel supply, combustion air system and exhaust system.
 - Only original accessories and original spare parts must be used during installation or repairs.
 - When carrying out electric welding on the vehicle, the plus pole cable at the battery should be disconnected and placed at ground to protect the controller.
 - Do not operate the heater anywhere where there are readily flammable materials (e.g. dry grass, leaves, paper, etc.) in the area of the exhaust system or where ignitable fumes and dust can form, e.g. near a
 - fuel depot
 - coal depot
 - wood depot
 - grain depots, etc.



Caution!

Safety instructions for installation and operation!

- The year of initial commissioning must be marked on the nameplate.
 - The heat exchanger of air heaters is a component subject to high thermal loads which must be replaced 10 years after initial commissioning of the heater. In addition, the installation date must be entered on the plate "original spare part" enclosed with the heat exchanger must. Then affix the plate next to the nameplate on the heater.
 - The heater must only be installed by a JE partner authorised by the manufacturer according to the instructions in this manual and possibly according to special installation recommendations; the same applies to any repairs to be carried out in the case of repairs or guarantee claims.
 - Only the control elements approved by Eberspächer Climate Control Systems GmbH & Co. KG. must be used to operate the heater. The use of other control elements can cause malfunctions.
 - Repairs by unauthorised third-parties or with not original spare parts are dangerous and therefore not allowed. They result in expiry of the type permit of the heater; consequently, when installed in motor vehicles they can cause expiry of the vehicle operating licence.
- Please note!**
- Following installation, attach the „Switch off heater before refuelling!“ sticker near the tank filler neck.

Accident prevention

General accident prevention regulations and the corresponding workshop and operation safety instructions are to be observed.

2 Product information

Heater scope of supply, complete packages and universal installation kit

Heater	Order No.
Airtronic D2, 12 V	25 2069 05 00 00
Airtronic D2, 24 V	25 2070 05 00 00
Airtronic B3 Plus, 12 V	20 1944 05 00 00
Airtronic D3, 12 V	25 2317 05 00 00
Airtronic B4, 12 V	20 1812 05 00 00
Airtronic D4, 12 V	25 2113 05 00 00
Airtronic D4, 24 V	25 2114 05 00 00
Airtronic D4 Plus, 12 V	25 2484 05 00 00
Airtronic D4 Plus, 24 V	25 2498 05 00 00

The scope of supply includes:

No. in figure	Name
1	Heater
2	Metering pump

Complete Airtronic D2 package	Order No.
12 V with mini controller	25 2115 05 00 00
12 V with EasyStart Select	25 2675 05 00 00
24 V with mini controller	25 2116 05 00 00
24 V with EasyStart Select	25 2676 05 00 00

Included in the scope of supply:

No. in figure	Name
1	Heater
2	Metering pump
-	Installation kit with outlet hood Ø 60 mm
3	EasyStart Select or
4	Mini-controller
5	Tank connection (only in complete package Airtronic D2, 24 V)

Universal installation kit (all versions)

Included in the scope of supply:

No. in figure	Name
6	Lead harness, operation
7	Flexible exhaust pipe, 1 m long
8	Combustion air hose, 1 m long
9	Cable tie (10x)
10	Bracket, dosing pump
11	Pipe, 6 x 2, 1.5 m long
12	Pipe, 4 x 1.25, 7.5 m long
13	Hose clip (2x)
14	Air outlet, rotatable
15	Grid
16	Hood
17	Flexible pipe
18	Exhaust silencer

- 19 Cable harness, heater
- 20 Lead harness, plus / minus

Using the universal installation kits

Universal installation kit Order No.
25 2069 80 00 00

- with outlet hood Ø 60 mm, heater guide number 6, usable with:
 - Airtronic D2, 12 V 25 2069 05 00 00
 - Airtronic D2, 24 V 25 2070 05 00 00

Universal installation kit **25 2113 80 00 00**

- with outlet hood Ø 90 mm, heater guide number 10, usable with:
 - Airtronic D3, 12 V 25 2317 05 00 00
 - Airtronic B4, 12 V 20 1812 05 00 00
 - Airtronic D4, 12 V 25 2113 05 00 00
 - Airtronic D4, 24 V 25 2114 05 00 00

- with outlet hood Ø 90 mm, heater guide number 15, usable with:
 - Airtronic D4 Plus, 12 V 25 2484 05 00 00
 - Airtronic D4 Plus, 24 V 25 2498 05 00 00

- with outlet hood Ø 90 mm, heater guide number 30, usable with:
 - Airtronic B3 Plus, 12 V 20 1944 05 00 00

Universal installation kit **25 2484 80 00 00**

- with outlet hood Ø 75 mm, heater guide number 3, usable with:
 - Airtronic D3, 12 V 25 2317 05 00 00
 - Airtronic B4, 12 V 20 1812 05 00 00
 - Airtronic D4, 12 V 25 2113 05 00 00
 - Airtronic D4, 24 V 25 2114 05 00 00

- with outlet hood Ø 75 mm, heater guide number 8, for recirculation mode heater guide number 10, for fresh air mode usable with:
 - Airtronic B3 Plus, 12 V 20 1944 05 00 00
 - Airtronic D4 Plus, 12 V 25 2484 05 00 00
 - Airtronic D4 Plus, 24 V 25 2498 05 00 00

Please note!

- Control elements see price list or product information.
- Parts without a figure no. are small parts and packed in a bag.
- If other parts are required for the installation, see product information.
- For notes on the unit ratings, refer to product information.

2 Product information



Scope of supply: Heater, universal installation kit and complete packages

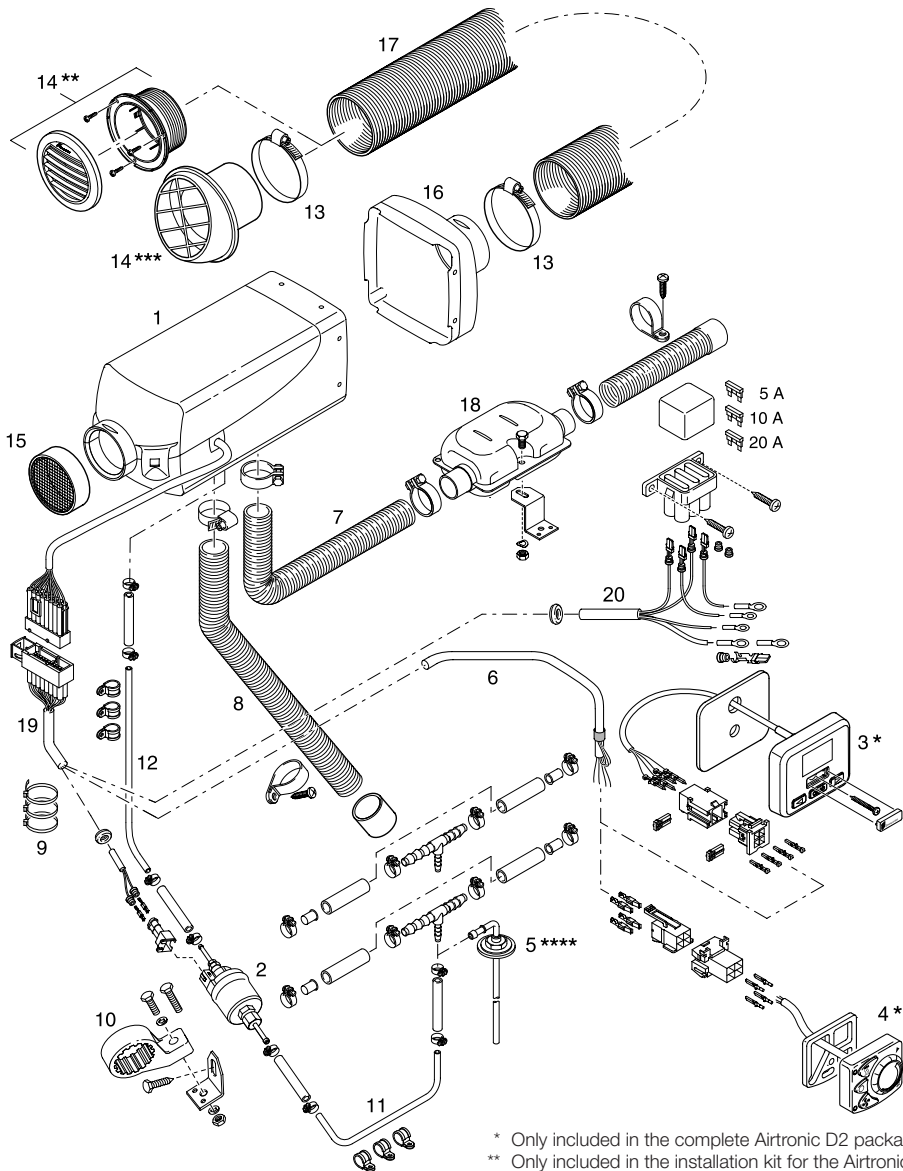

* Only included in the complete Airtronic D2 package.

** Only included in the installation kit for the Airtronic B3 Plus, D3, B4, D4, D4 Plus.

*** Only included in the installation kit for the Airtronic D2 and in the complete Airtronic D2 package.

**** Only included in the complete Airtronic D2, 24 volt package.

2 Product information

Scope of supply Heater and "Plus" installation kit

Heater	Order No.
Airtronic D2, 12 V	25 2069 05 00 00
Airtronic D2, 24 V	25 2070 05 00 00

The scope of supply includes:

No. in

figure Name

- | | |
|---|---------------|
| 1 | Heater |
| 2 | Metering pump |

"Plus" installation kit **25 2113 81 00 00**

- with outlet hood Ø 75 mm,
heater guide number 12,

The scope of supply includes:

figure Name

- | | |
|----|--|
| 3 | Combustion air intake silencer |
| 4 | Exhaust silencer |
| 5 | Hose connecting sockets |
| 6 | Grid |
| 7 | Y branch |
| 8 | Tank connection kit |
| 9 | Temperature control sensor |
| 10 | Cable loom for temperature control sensor |
| 11 | EasyStart T timer |
| 12 | Lead harness, plus / minus |
| 13 | Lead harness, operation |
| 14 | Hose clip (2x) |
| 15 | Hose clip (6x) |
| 16 | Pipe 4 x 1.25 , 6 m long, (included in Item 8) |
| 17 | Cable harness, heater |
| 18 | Flexible exhaust pipe, 1 m long |
| 19 | Grid |
| 20 | Bracket metering pump |
| 21 | Cable tie (10x) |
| 22 | Hood |
| 23 | Outlet (2x) |
| 24 | Adapter Ø 6 / 4 |
| 25 | Pipe 4 x 1, 6 m long, (included in Item 8) |
| 26 | Pipe clip, Ø 50 mm |
| 27 | Flexible pipe for hot air system |

Please note!

- Parts without a figure no. are small parts and packed in a bag.
- If other parts are required for the installation, see product information.
- For notes on the unit ratings, refer to product information.
- The "Plus" installation kits are particularly suitable for installations in camper vans and boats.



2 Product information

Scope of supply: Heater and “Plus” installation kit

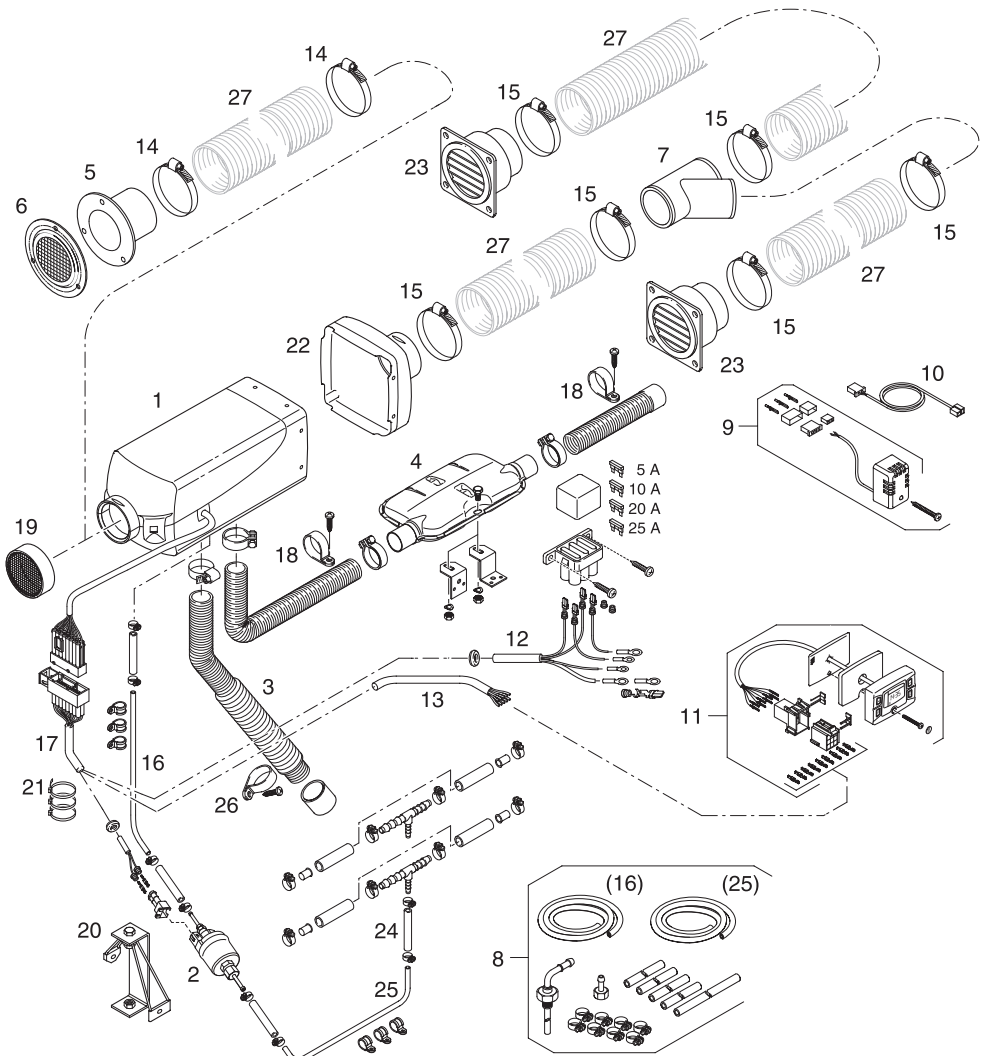

2 Product information

Technical data

Heater type	Airtronic				
Heater	Airtronic D2				
Version	D2				
Heating medium	Air				
Control of the heat flow	Stage				
	Power	Large	Medium	Small	Off
Heat flow (watt)	2200	1800	1200	850	–
Heater air flow rate without counterpressure (kg/h) with hood Ø 60 mm	105	87	60	42	13
Fuel consumption (l/h)	0,28	0,23	0,15	0,10	–
Elektr. power consumption (watt)	in operation	34	23	12	8
Rated voltage	12 or 24 volt				
Operating range	approx. 10.5 volt resp. 21 volt Undervoltage protection trigger time: 20 seconds				
<ul style="list-style-type: none"> Lower voltage limit: An undervoltage protection in the controller switches off the heater when the voltage limit is reached. 					
<ul style="list-style-type: none"> Upper voltage limit: An overvoltage protection in the controller switches off the heater when the voltage limit is reached. 	approx. 16 volt resp. 32 volt Overvoltage protection trigger time: 20 seconds				
Fuel “Fuel quality” and “Fuel at low temperatures” see page 28.	Commercially available diesel fuel (DIN EN 590)				
Tolerable ambient temperature	Operation		Not running		
	Heater	–40 °C to +70 °C	–40 °C to +85 °C		
	Dosing pump	–40 °C to +50 °C	–40 °C to +125 °C		
Maximum air intake temperature	+40 °C				
Interference suppression	Interference suppression class 5 to DIN EN 55 025				
Weight	approx. 2,7 kg				
Ventilation mode	possible				



Caution!

Safety instructions for technical data!

Failure to comply with the technical data can result in malfunctions.

Please note!

Provided no limit values are given, the technical data listed is subject to the tolerances usually applicable to heaters of ±10% for nominal voltage, ambient temperature 20 °C and reference altitude Esslingen.



2 Product information

Technical data

Heater type		Airtronic M				
Heater		Airtronic D3 / Airtronic D4 / Airtronic D4 Plus				
Version		D3 / D4 / D4 Plus				
Heating medium		Air				
Control of the heat flow		Stage				
		Power	Large	Medium	Small	Off
Heat flow (watt)	D3	3000	2200	1600	900	–
	D4	4000	3000	2000	900	–
	D4 Plus	4000	3000	2000	900	–
Heater air flow rate without counterpressure (kg/h)						
	D3 with hood Ø 90 mm	150	120	90	60	24
	D4 with hood Ø 90 mm	185	150	110	60	22
	D4 Plus with hood Ø 75 mm	185	140	100	55	–
Fuel consumption (l/h)	D3	0,38	0,28	0,24	0,11	–
	B4	0,51	0,38	0,25	0,11	–
	D4 Plus	0,51	0,38	0,25	0,11	–
Elektr. power consumption (watt) in operation (12 and 24 volt)	D3	24	16	10	7	5
	B4	40	24	13	7	5
	D4 Plus	55	30	16	7	5
at start (12 and 24 volt)		≤100				
Rated voltage		12 or 24 volt				
Operating range						
<ul style="list-style-type: none"> Lower voltage limit: An undervoltage protection in the controller switches off the heater when the voltage limit is reached. 		approx. 10.5 volt resp. 21 volt Undervoltage protection trigger time: 20 seconds				
<ul style="list-style-type: none"> Upper voltage limit: An overvoltage protection in the controller switches off the heater when the voltage limit is reached. 		approx. 16 volt resp. 32 volt Overvoltage protection trigger time: 20 seconds				
Fuel "Fuel quality" and "Fuel at low temperatures" see page 28.		Commercially available diesel fuel (DIN EN 590)				
Tolerable ambient temperature		Operation		Not running		
	Heater	–40 °C to +70 °C		–40 °C to +85 °C		
	Dosing pump	–40 °C to +50 °C		–40 °C to +125 °C		
Maximum air intake temperature		+40 °C				
Interference suppression		Interference suppression class 5 to DIN EN 55 025				
Weight		approx. 4,5 kg				
Ventilation mode		possible				

Please note!

Safety instructions for technical data see page 12.

2 Product information

Technical data

Heatertyp		Airtronic M				
Heater		Airtronic B3 Plus / Airtronic B4				
Version		B3 Plus / B4				
Heating medium		Air				
Control of the heat flow		Stage				
		Power	Large	Medium	Small	Off
Heat flow (watt)	B3 Plus	3000	2300	1700	1200	–
	B4	3800	3200	2100	1300	–
Heater air flow rate without counterpressure (kg/h)		B3 Plus with hood Ø 90 mm				
		175	143	115	85	24
		B4 with hood Ø 90 mm				
		185	160	120	85	24
Fuel consumption (l/h)	B3 Plus	0,43	0,33	0,24	0,16	–
	B4	0,54	0,46	0,29	0,18	–
Elektr. power consumption (watt) in operation	B3 Plus	33	20	13	8	5
	B4	40	29	15	9	5
	at start	≤100				
Rated voltage		12 volt				
Operating range		approx. 10.5 volt Undervoltage protection trigger time: 20 seconds				
<ul style="list-style-type: none"> Lower voltage limit: An undervoltage protection in the controller switches off the heater when the voltage limit is reached. 						
<ul style="list-style-type: none"> Upper voltage limit: An overvoltage protection in the controller switches off the heater when the voltage limit is reached. 		approx. 16 volt Undervoltage protection trigger time: 20 seconds				
Fuel "Fuel quality" and "Fuel at low temperatures" see page 28.		Commercially available petrol fuel (DIN EN 228)				
Tolerable ambient temperature		Operation		Not running		
		Heater	–40 °C to +50 °C	–40 °C to +85 °C		
		Dosing pump	–40 °C to +20 °C	–40 °C to +125 °C		
Maximum air intake temperature		+40 °C				
Interference suppression		Interference suppression class 5 to DIN EN 55 025				
Weight		approx. 4,5 kg				
Ventilation mode		possible				



Caution!

Safety instructions for technical data!

Failure to comply with the technical data can result in malfunctions.

Please note!

Provided no limit values are given, the technical data listed is subject to the tolerances usually applicable to heaters of ±10% for nominal voltage, ambient temperature 20 °C and reference altitude Esslingen.

3 Installation

Installation and mounting position

The heater is suitable and approved for installation in vehicle interiors used by people.

The heater, together with its heater flange and the mounted flange seal, is fixed directly onto the floor of the vehicle or in a suitable position in the rear panel of the vehicle.

Please note!

- If installed inside the vehicle, detachable connections of exhaust gas, combustion air and fuel lines are **not** allowed.
- The flange seal must be mounted on the heater, in order to seal off the openings for the exhaust gas, combustion air and fuel lines.
- Installation in the driver's cab or passenger compartment of commercial buses with more than 9 seats (8 seats + driver's seat) is not allowed.
- The ADR regulations must also be complied with for installation of the heater in vehicles used to transport dangerous goods.
For information on the ADR regulations, see page 6, 31 and in the information sheet with Print No. 25 2161 95 15 80.
- When installing the heater, ensure sufficient open space is allowed for intake of the heating air and for the dismantling of glow plugs and control box (see page 15 "main dimensions").
- Observe the regulations and safety instructions for this chapter, given on pages 4 – 7.

Installation position in a camper van

In a camper van, the heater is preferably installed in the inner compartment or luggage compartment. If it is not possible to install the heater in the passenger compartment or boot, the heater can also be mounted, protected against splashing water, under the vehicle floor.

Please note!

The „Plus“ installation kits are intended for installation in a camper van.

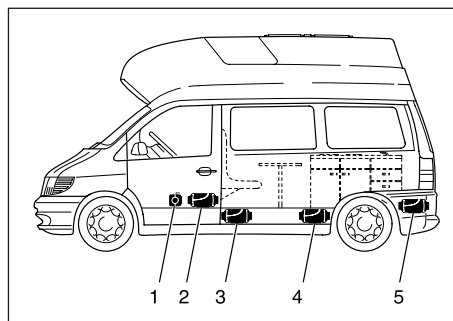

- 1 Heater in front of the passenger seat
- 2 Heater between the driver's seat and the passenger seat
- 3 Heater under the vehicle floor
- 4 Heater in living space
- 5 Heater in the boot



3 Installation

Installation

Installation in a car or people carrier

In a car or people carrier, the heater is preferably installed in the passenger compartment or boot. If it is not possible to install the heater in the passenger compartment or boot, the heater can also be mounted, protected against splashing water, under the vehicle floor.

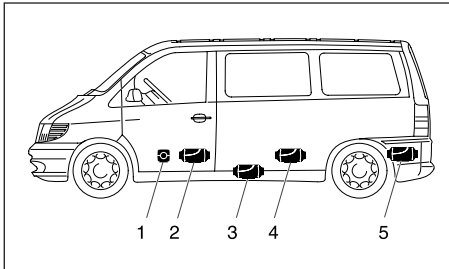

- 1 Heater in front of the passenger seat
- 2 Heater between the driver's seat and the passenger seat
- 3 Heater under the vehicle floor
- 4 Heater under the back seat
- 5 Heater in the boot

Installation in an excavator cab (only diesel heaters)

In an excavator, the heater is preferably installed in the cab. If it is not possible to install the heater in the cab, the heater can also be installed in a storage box outside the cab.

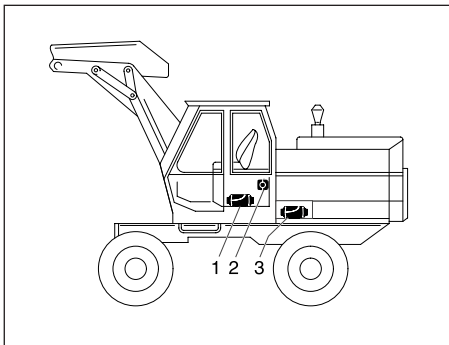

- 1 Heater in the seat box
- 2 Heater on the cab rear wall
- 3 Heater in a protective case

Installation in a truck (only diesel heaters)

In a truck, the heater is preferably installed inside the driver's cab. If it is not possible to install the heater inside the driver's cab, it can also be mounted in the tool box or in a storage box.

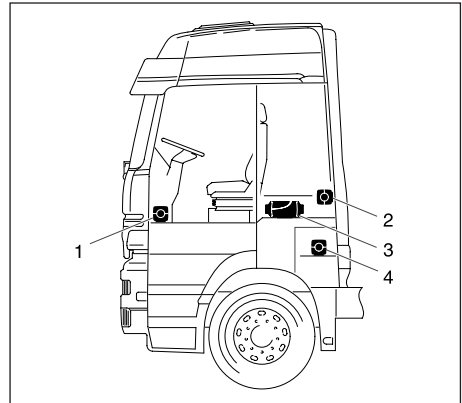

- 1 Heater in the passenger's foot room
- 2 Heater on the cab rear wall
- 3 Heater under the bed
- 4 Heater in the tool box

Please note!

- The installation suggestions made in the installation instructions are just examples. Other installation locations are possible, as long as they correspond to the installation requirements stated in these instructions.
- Other installation information (e.g. for boats and ships) is available from the manufacturer on request.
- Observe the tolerable installation position together with the operating and storage temperatures.

3 Installation

Possible installation positions

The heater is preferably installed in the normal position as shown in the drawing.

Depending on the installation conditions, the heater can be tilted by max. 30° (flow direction to the bottom) or turned by max. 90° around its own longitudinal axis (exhaust connection horizontal, glow plug points upwards!).

Please note!

In the heating mode, the heater can deviate from the shown normal or maximum installation positions by up to +15° in all directions because of a slanting position of the vehicle or boat, without any impaired functions.

Normal position horizontal (exhaust connection downwards) with tolerable swivel range

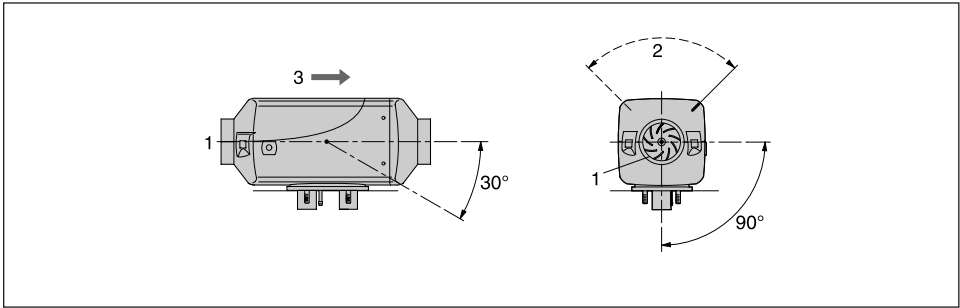

- 1 Heater air intake opening (fan wheel)
- 2 Position of the glow plug
- 3 Direction of flow

Cable harness connection, optionally right or left

If necessary, the cable harness connection can be changed over to the other side of the heater. To do so, the controller has to be removed and the lower semi-circular cable harness cover unclipped.

The cable harness can then be rerouted in the controller.

Then mount the controller again, position the jacket shell and insert the cable harness bush and the bungs in the corresponding recesses in the lower jacket shell.

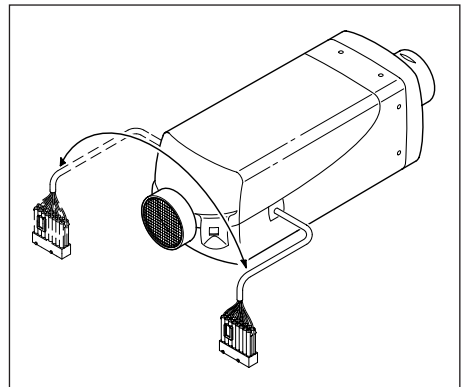



3 Installation

Mounting and fastening

Make the necessary breakthroughs for exhaust, combustion air and fuel as shown in the hole diagram. The support surface for the heater foot must be flat. An appropriate tool can be purchased from the manufacturer for drilling the breakthroughs and also smoothing the support surface. The hole $\varnothing 10.5$ mm for the cable harness "dosing pump" is not included in the picture drawing and must be drilled after installation.

If the sheet metal of the support surface is <1.5 mm thick, an additional reinforcement must be installed.

Order no: reinforcement plate 20 1577 89 00 03
Order no: special tool 99 1201 46 53 29

Picture hole

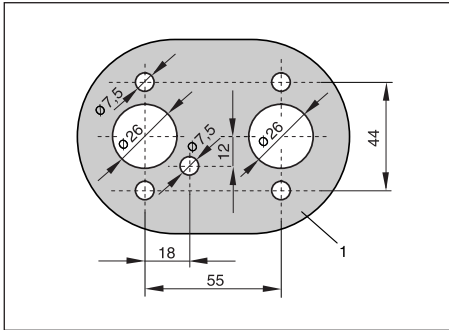

1 Contour of the bearing surface

Special tool

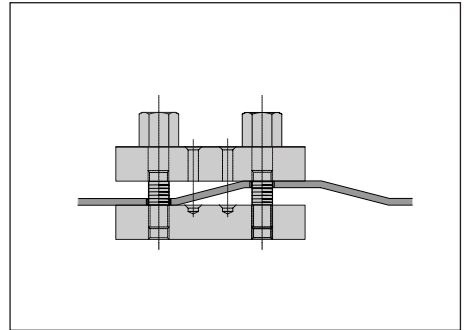

Fastening the unit on the vehicle floor

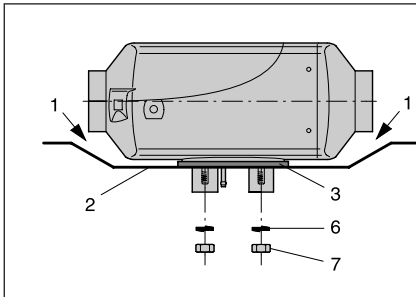

- 1 There must be sufficient clearance between the heater and the vehicle floor – also check that the fan wheel runs freely.
- 2 The mounting surface must be flat and smooth.
- 3 The flange seal must be mounted.

Fastening the heater horizontally to the vehicle wall

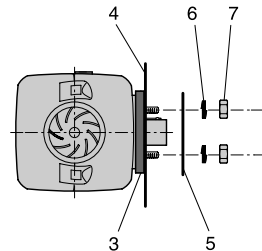

- 4 The vehicle wall must be flat and smooth.
- 5 Reinforcement plate (if required, for Order No. see above)
- 6 Spring washer
- 7 Hexagon nut M6 (torque 5^{+1} Nm)

3 Installation

Nameplate

The nameplate is fastened to the front of the heater. The second nameplate (duplicate) is included in the scope of supply of the heater. If required, the duplicate nameplate can be adhered in a clearly visible position on the heater or near to the heater.

Please note!

The regulations and safety instructions to be observed for this chapter are stated on page 5.

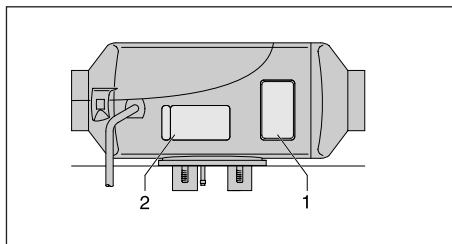

- 1 Original nameplate
- 2 2nd nameplate (duplicate)



3 Installation

Heater air system

The parts for the hot air system are included in the scope of supply of the „Universal“ and „Plus“ installation kits.

The „Plus“ installation kit does not contain any flexible pipes, these must be ordered separately. Refer to the product information for the Order No.



Danger!

Risk of burning and injuries!

- The hoses of the heater air system and the hot air outlet are to be routed and fastened in such a way that they pose no temperature risk to people, animals or materials sensitive to temperature from radiation / contact or blowing directly. If necessary, a cover is to be fitted to the heater air system or hot air outlet.
- The outflow hood must be fitted on the hot air outflow side.
- A safety grid must be fitted to the heater air intake side and outflow side if no air hoses are mounted, to prevent any injuries from the heater air fan or burns from the heat exchanger.
- High temperatures occur in the heater air system during and after the heater has been working. This is why it is important to avoid working in the vicinity of the heater air system while the heater is working. In such cases, switch the heater off beforehand and wait until all parts have cooled down completely. If necessary, wear safety gloves.

Please note!

- Installation of spherical reduction hood is not permitted in the Airtronic D4 Plus.
- The regulations and safety instructions to be observed for this chapter are on page 4 – 7.
- If air duct parts are connected the heater code number in “Using Universal Installation Kits”, page 8 and “Using Plus Installation Kits”, page 10 must be observed.



Caution!

- The heater air intake openings must be arranged in such a way that under normal circumstances, it is not possible for exhaust from the vehicle engine and heater to be sucked into the system, or for the heating air to be contaminated with dust, salt spray, etc.
- For circulating air, position the circulating air intake in such a way that the outflowing hot air cannot be directly sucked in again.
- In the event of possible overheating, it is possible for local hot air temperatures of up to max. 150 °C or surface temperatures of up to max. 90 °C to occur immediately before the defect shutdown. Therefore only temperature-resistant hot air hoses approved by us must be used for the heater air system!
- When checking the functions, the mean outflow temperature measured after the heater has been running about 10 minutes at approx. 30 cm from the outlet should not exceed 110 °C (at an intake temperature of approx. 20 °C).
- If there is a risk of the driver and passengers touching the heater when the vehicle is being driven normally, a contact protection device must be fitted.

Heater air system (example)

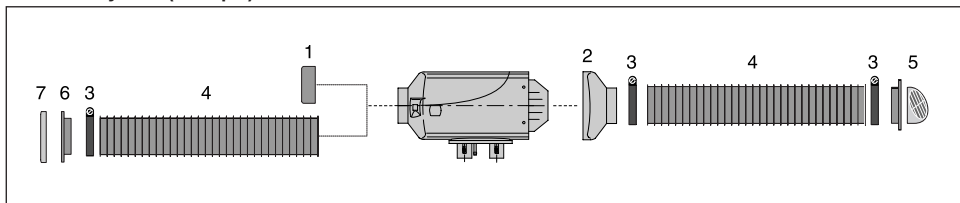

- | | |
|-----------------|----------------------|
| 1 Safety grid | 5 Rotating outflow |
| 2 Outflow hood | 6 Connection fitting |
| 3 Hose clip | 7 Safety grid |
| 4 Flexible hose | |

3 Installation

Exhaust system

Mounting the exhaust system

The "Universal" and "Plus" installation kits include a flexible exhaust pipe, inner \varnothing 24 mm, 1000 mm long and an exhaust silencer. The flexible exhaust pipe can be shortened to 20 cm or lengthened to max. 2 m, depending on the installation conditions. Fasten the exhaust silencer to a suitable position in the vehicle.

Use a pipe clip to fix a short exhaust pipe end (with end sleeve) to the exhaust silencer (Anzugsdrehmoment $7^{+0.5}$ Nm).

Use a pipe clip (tightening torque $7^{+0.5}$ Nm) to fix a short exhaust end pipe (with end sleeve) to the exhaust silencer.



Caution!

Safety instructions!

The whole exhaust system gets very hot during and immediately after the heater has been working. This is the reason why the exhaust system must be installed according to these instructions.

- The exhaust outlet must end in the open air.
- The exhaust pipe must not protrude beyond the lateral limits of the vehicle.
- Install the exhaust pipe sloping slightly downwards. If necessary, make a drain hole approx. \varnothing 5 mm at the lowest point to drain off condensation.
- Important functional parts of the vehicle must not be impaired (keep sufficient clearance).
- Mount the exhaust pipe with sufficient clearance to heat-sensitive parts. Pay particular attention to fuel pipes (plastic or metal), electrical cables and brake hoses etc.!
- Exhaust pipes must be fastened safely (recommended clearance of 50 cm) to avoid damage from vibrations.
- Route the exhaust system so that the emitted fumes are not sucked in with the combustion air.
- The mouth of the exhaust pipe must not get clogged by dirt and snow.
- The mouth of the exhaust pipe must not point in the direction of travel.
- Always fasten the exhaust silencer to the vehicle.



Danger!

Risk of injuries and burns!

Every type of combustion produces high temperatures and toxic exhaust fumes. This is the reason why the exhaust system must be installed according to these instructions.

- Do not perform any work on the exhaust system while the heater is working.
- Before working on the exhaust system, first switch the heater off and wait until all parts have cooled down completely, wear safety gloves if necessary.
- Do not inhale exhaust fumes.

Please note!

- Comply with the regulations and safety instructions for this chapter on page 4 – 7.
- If a silencer is fitted, the exhaust end pipe must be much shorter than the flexible exhaust pipe between the heater and the exhaust silencer.
- Small arrows indicating the direction of flow have been cast into the fittings to differentiate between the combustion air and the exhaust fittings at the heater (see diagram page 23).
- To prevent contact erosion, the clips used to fix the exhaust pipe must be made of stainless steel. The order No. for the stainless steel fixing clips is given in the product information.



3 Installation

Combustion air system

Mounting the combustion air system

The universal installation kit includes a flexible combustion air hose, inner $\text{\O} 25 \text{ mm}$, 1000 mm long. If necessary the flexible combustion air hose can be shortened to 20 cm or lengthened to max. 2 m depending on the installation conditions.

Use a pipe clip (tightening torque $3^{+0.5} \text{ Nm}$) to fix the flexible combustion air hose to the heater and use hose clips or cable ties to fix in suitable positions. Fit an end sleeve after completing the installation.

The „Plus“ installation kit includes a combustion air intake silencer with a flexible connection hose (inner diameter 25 mm).

Use a pipe clip (tightening torque $3^{+0.5} \text{ Nm}$) to fix the flexible connection hose to the heater and use hose clips or cable ties to fix in suitable positions. Fit an end sleeve after completing the installation.



Caution!

Safety instructions for the combustion air system!

- The combustion air opening must be free at all times.
- Position the combustion air intake to be sure that exhaust fumes cannot be sucked in with the combustion air.
- Do not arrange the combustion air intake to pointing against the wind blast.
- The combustion air intake must not get clogged with dirt and snow.
- Install the combustion air intake system sloping slightly downwards. If necessary, make a drain hole approx. $\text{\O} 5 \text{ mm}$ at the lowest point to drain off condensation.

Please note!

- For Airtronic and Airtronic M heaters a combustion air intake silencer can be fitted instead of the combustion air hose to reduce the noise level. Order No. see spare parts list or product information.
- Comply with the regulations and safety instructions for this chapter on page 4 – 7.

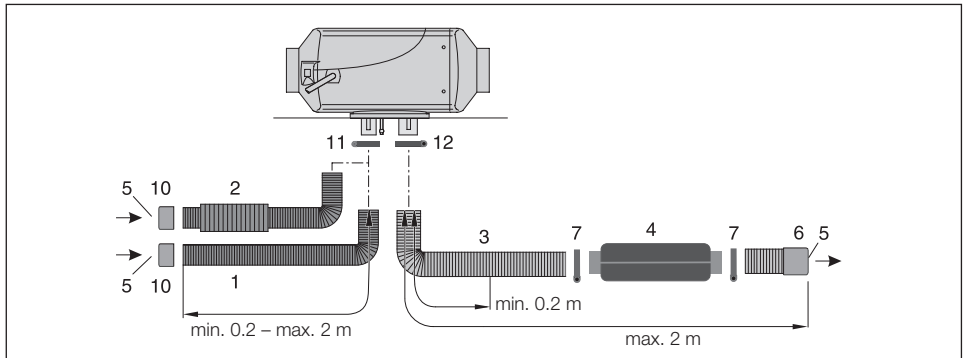

- 1 Combustion air hose, di = 25 mm
- 2 Combustion air silencer,
– Included in the „Plus“ installation kit
- 3 Exhaust pipe, di = 24 mm
- 4 Exhaust silencer
- 5 Intake / outlet opening – protect from wind, snow, dirt and water.
- 6 End sleeve, combustion air
- 7 End sleeve, exhaust
- 8 Combustion air connection
- 9 Exhaust connection
- 10 End sleeve, combustion air
- 11 Hose clip
- 12 Exhaust hose clip

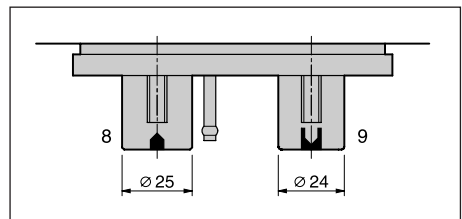

3 Installation

Fuel supply

Mounting the dosing pump, routing the fuel pipes and mounting the fuel tank

The following safety instructions must be observed when mounting the dosing pump, routing the fuel pipes and mounting the fuel tank. Deviations from the instructions stated here are not allowed.

Failure to comply can result in malfunctions.



Danger!

Risk of fire, explosion, poisoning and injuries!

Caution when handling fuel.

- Switch off the vehicle engine and heater before refueling and before working on the fuel supply.
- No naked lights when handling fuel.
- Do not smoke.
- Do not inhale fuel vapours.
- Avoid any contact with the skin.



Caution!

Safety instructions for routing the fuel pipes!

- Only use a sharp knife to cut off fuel hoses and pipes. Interfaces must not be crushed and must be free of burrs.
- The fuel pipe from the dosing pump to the heater should be routed at a continuous rise.
- Fuel pipes must be fastened safely to avoid any damage and / or noise production from vibrations (recommended clearance of approx. 50 cm).
- Fuel pipes must be protected from any mechanical damage.
- Route the fuel pipes so that any distortion of the vehicle, engine movements etc. can not have any lasting effect on the service life.
- Use hose clips to secure all hose connections in the fuel supply (tightening torque $1^{+0.2}$ Nm).
- Parts carrying fuel must be protected from interfering heat.

- Never route or fasten the fuel pipes to the heater or vehicle exhaust system. At crossings, always ensure adequate heat clearance, if necessary attach heat deflection plates or protective hose (For Order No. of protective hose, see product information).
- Dripping or evaporating fuel must never be allowed to collect on hot parts or ignite on electric systems.
- When connecting fuel pipes with a fuel hose, always mount the fuel pipes in a butt joint to prevent any bubbles from forming.

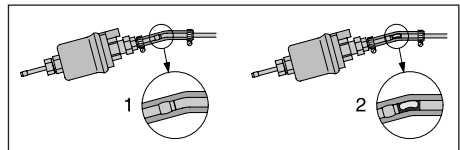

- 1 Correct connection
- 2 Incorrect connection – bubble formation

Safety instructions for fuel pipes and fuel tanks in buses and coaches

- In buses and coaches, fuel pipes and fuel tanks must not be routed through the passenger compartment or driver's cab.
- Fuel tanks in buses and coaches must be positioned in such a way that the exits are not in direct danger from a possible fire.

Please note!

- Comply with the regulations and safety instructions for this chapter on page 4 – 7.
- For noise reasons, do not rigidly fit fuel pipes onto structural sound transferring components. A sponge rubber hose can be pushed over the fuel tubes for noise reduction.



3 Installation

Fuel supply

Fuel feed point with T-piece from the fuel supply line from the tank fitting to the vehicle engine

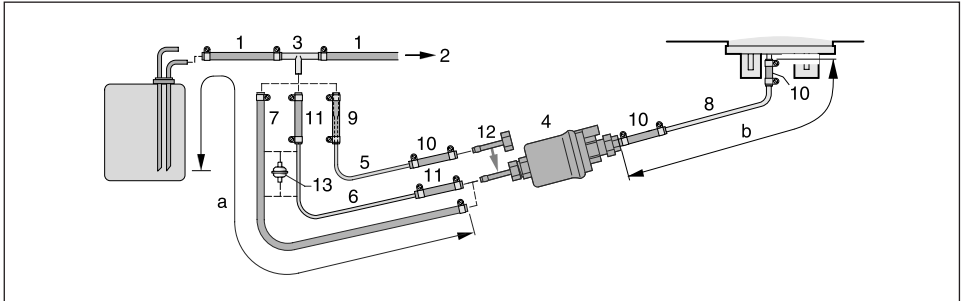

- 1 Fuel flow line, vehicle tank
- 2 To the vehicle's engine, mechanical fuel or injection pump
- 3 T-piece, 8-6-8 or 10-6-10
- 4 Dosing pump
- 5 Fuel pipe, 4 x 1 (di = Ø 2 mm)
- 6 Fuel pipe, 6 x 2 (di = Ø 2 mm)
- 7 Fuel hose, 5 x 3 (di = Ø 5 mm)
- 8* Fuel pipe, 4 x 1.25 (di = Ø 1,5 mm)
- 9 Adapter Ø 6 / 4
- 10 Fuel hose, 3,5 x 3 (di = Ø 3,5 mm), approx. 50 mm long
- 11 Fuel hose, 5 x 3 (di = Ø 5 mm), approx. 50 mm long
- 12 Pipe connectors, da = Ø 4 mm
- 13 Fuel filter - required for contaminated fuel only.

* If necessary, a fuel pipe 4 x 1 (di = Ø 2 mm) can be used for diesel heaters instead of the fuel pipe 4 x 1.25 (di = Ø 1,5 mm), Item (8). The details regarding the pipe lengths remain unchanged. The fuel pipe, 4 x 1 must be order separately. Order No. see spare parts list or product information.

Possible pipe lengths

Intake side

Airtronic
a = max. 5 m

Airtronic M
a = max. 2 m

Pressure side

Diesel heaters
• For suction pipe di = Ø 2 mm, b = max. 6 m
• For suction pipe di = Ø 5 mm, b = max. 10 m

Petrol heater
• b = max. 4 m

Please note!

- Insert the T-piece (3) in the fuel flow line upstream of the feed pump.
- Items (5), (9) and (12) are included in the „Plus“ installation kit only.
- Item (6) is included in the universal installation kit only.
- Items (7) and (13) must be ordered separately. The order no. is given in the product information.

Installation position of the T-piece

Use the installation positions shown in the diagram when inserting a T-piece.

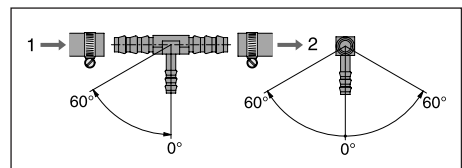

- 1 Direction of flow from the fuel tank
- 2 Direction of flow to the vehicle engine

3 Installation

Fuel supply

Fuel feed point with tank connection – ascending pipe, integrated in the vehicle tank or in the tank fitting

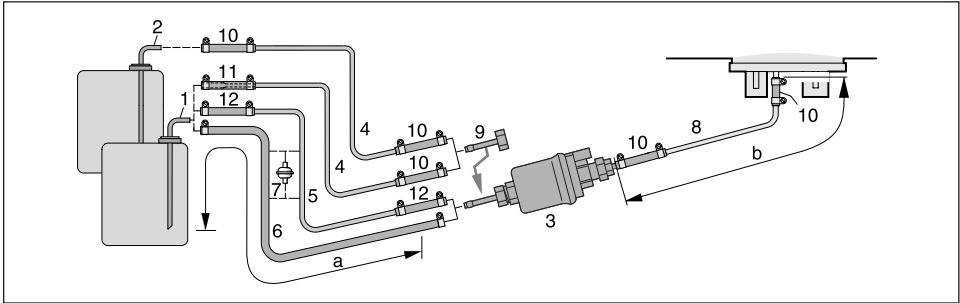

- 1 Tank connection for metal tank -
di = Ø 2 mm, da = Ø 6 mm
- 2 Tank connection for tank fitting -
di = Ø 2 mm, da = Ø 4 mm
- 3 Dosing pump
- 4 Fuel pipe, 4 x 1 (di = Ø 2 mm)
- 5 Fuel pipe, 6 x 2 (di = Ø 2 mm)
- 6 Fuel hose, 5 x 3 (di = Ø 5 mm)
- 7 Fuel filter - required for contaminated fuel only.
- 8* Fuel pipe, 4 x 1.25 (di = Ø 1,5 mm)
- 9 Pipe connectors, da = Ø 4 mm
- 10 Fuel hose, 3,5 x 3 (di = Ø 3.5 mm)
approx. 50 mm long
- 11 Adapter Ø 6 / 4
- 12 Fuel hose, 5 x 3 (di = Ø 5 mm),
approx. 50 mm long

* If necessary, a fuel pipe 4 x 1 (di = Ø 2 mm) can be used for diesel heaters instead of the fuel pipe 4 x 1.25 (di = Ø 1.5 mm), Item (8).

The details regarding the pipe lengths remain unchanged.

The fuel pipe, 4 x 1 must be order separately. Order No. see spare parts list or product information.

Possible pipe lengths

Intake side

Airtronic
a = max. 5 m

Airtronic M
a = max. 2 m

Pressure side

Diesel heaters

- For suction pipe di= Ø 2 mm,
b = max. 6 m

- For suction pipe di= Ø 5 mm,
b = max. 10 m

Petrol heater

- b = max. 4 m

Please note!

- Items (2), (4), (8), (9) and the connection parts are included in the "Tank Connection" kit, Order No. 22 1000 20 13 00 (The "Tank Connection" kit is included in the „Plus“ installation kit).
- Item (5) is included in the universal installation kit only.
- Item (11) is included in the "Plus" installation kit only.
- Items (6) and (7) must be ordered separately. The order no. is given in the product information.
- When installing tank connection maintain a minimum distance of 50 ± 2 mm from the end of the riser pipe and the bottom of the tank.
- Consult the vehicle manufacturer before installing the tank connection in a metal tank.



Caution!

Safety instructions for the fuel supply!

- The fuel must not be conveyed by gravity or overpressure in the fuel tank.
- Withdrawal of fuel after the vehicle's fuel pump is not allowed.
- When the pressure in the fuel pipe is more than 0.2 bar to max. 4.0 bar, use a pressure reducer (order no. 22 1000 20 08 00) or separate tank connection.
- When the pressure in the fuel pipe is more than 4.0 bar or there is a non-return valve in the return pipe (in the tank), a separate tank connection must be used.
- When using a T-piece in a plastic pipe, always use support sleeves in the plastic. Connect the T-piece and the plastic pipe with corresponding fuel hoses and secure with hose clips.



3 Installation

Fuel supply

Installation position of the dosing pump

Always mount the dosing pump with the pressure side rising upwards. Every installation position over 15° is allowed, although an installation position between 15° and 35° is preferable.

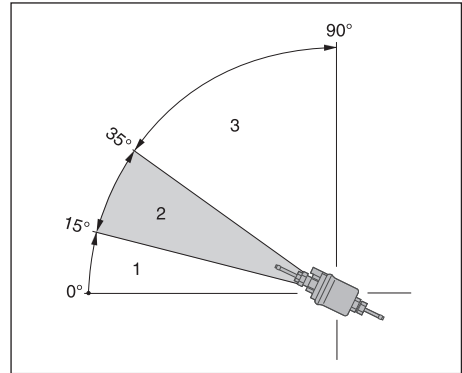

- 1 Installation position between 0° and 15° is not allowed.
- 2 Preferred installation position in range 15° to 35°.
- 3 Installation position in range 35° to 90° is allowed.

Possible suction and pressure height of the dosing pump

Pressure height from vehicle tank to dosing pump:
a = max. 3000 mm

Intake height in pressure-less vehicle tank:
b = max. 1000 mm for diesel
b = max. 500 mm for petrol

Intake height in vehicle tanks with withdrawal by negative pressure (valve with 0.03 bar in tank cap):
b = max. 400 mm

Pressure height of the dosing pump to the heater:
c = max. 2000 mm

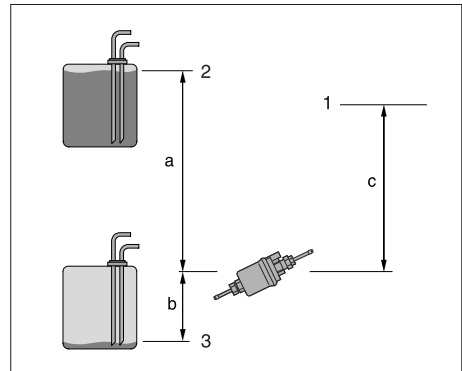

- 1 Connection to heater
- 2 Max. fuel level
- 3 Min. fuel level

Please note!

Check tank venting.



Caution!

Safety instructions for installing the dosing pump

- Always mount the dosing pipe with the pressure side rising upwards – minimum incline 15°.
- Protect the dosing pump and filter from intolerable heat, do not mount near to the silencers and exhaust pipes.

3 Installation

Fuel supply



Caution!

Fuel supply safety information

It is not permitted to operate the heater with unapproved fuel / fuel mixtures or the addition of used oil. Failure to comply with this can lead to personal injuries as well as a malfunction or damage to the heater.

Only the fuel approved by the manufacturer or by the vehicle manufacturer is to be used.

Fuel quality for petrol heaters

The heater runs without problems on normal commercial petrol according to DIN EN 228.

Fuel quality for diesel heaters

- The heater runs without problems on normal commercial diesel fuel according to DIN EN 590.
During the winter months the diesel fuel is adapted to low temperatures from 0 °C to -20 °C. Problems can therefore only arise if outdoor temperatures are extremely low - which also applies to the vehicle's engine - please refer to the vehicle manufacturer's regulations.
- In special cases and at outdoor temperatures above 0 °C the heater can also be run on heating oil EL according to DIN 51603.
- If the heater is run from a separate tank, please comply with the following rules:
 - if outdoor temperatures over 0 °C,
Use diesel fuel according to DIN EN 590.
 - if outdoor temperatures from 0 °C to -20 °C,
Use winter diesel fuel according to DIN 590.
 - if outdoor temperatures -20 °C to -40 °C,
Use Arctic Diesel or Polar Diesel.

Please note!

After refuelling with winter or cold diesel, the fuel pipes and the metering pump must be filled with the new fuel by letting the heater run for 15 min!

Operation with biodiesel (FAME)

Airtronic

The heater is **not** approved for operation with bio diesel fuel (FAME). Up to 10 % bio diesel fuel (FAME) may be added.

Airtronic M

The diesel heater is approved for operation with bio diesel fuel (FAME) according to DIN EN 14 214.

Please note!

- Bio diesel fuel (FAME) according to DIN EN 14 214
 - during the winter months is adapted to low temperatures from 0 °C to -20 °C.
 - The Flowability reduces at temperatures below 0 °C.
- When using 100 % bio diesel, the heater should be operated twice a year with diesel fuel (in the middle and at the end of a heating period) in order to burn off any possible biodiesel residues deposited.
To do so, let the vehicle tank run almost empty and then fill with diesel fuel. While running on this tank filling, switch the heater on 2 to 3 times for 30 minutes at a time at the highest temperature setting.
- When operating with diesel / bio diesel mixtures of up to 50 % bio diesel, intermediate operation with pure diesel fuel is not necessary.



4 Operation and function

Operating instructions

The heater is operated by a control element. Detailed operating instructions are enclosed with the control unit.

Please note!

The workshop / garage installing the heater will issue you with the operating instructions.

Important instructions for operation

Safety checks before the start

After a lengthy period of non-use (summer months) check that all parts fit securely (tighten screws where necessary).

Check the fuel system visually for any leaks.

Heating at high altitudes

- up to 1500 m altitude, heating mode is possible without altitude adjustment.
- from 1500 m – 3000 m, heating mode for short stays (e.g. if crossing a pass or stopping for a break) is possible without adjusting the heater altitude. In case of a lengthy stay, e.g. winter camping, it is necessary to adjust the heater's altitude. The heater's altitude is adjusted by installing an air pressure sensor; this is included in the altitude kit – Order No. 22 1000 33 22 00.

Please note!

Heaters suitable for high altitudes are labelled with "H-Kit" on the side nameplate.

Initial commissioning

The following points are to be checked by the company installing the heater during initial commissioning.

- After installation of the heater, the coolant circuit and the whole fuel supply system must be vented carefully. Comply with the instructions issued by the vehicle manufacturer.
- During the trial run of the heater, check all water and fuel connections for leaks and firm fitting.
- If the heater shows a fault during operation, find and eliminate the cause of the fault using a diagnosis unit.

Please note!

During the initial start-up of the heater, odours can be produced for a short time. This is fully normal during the first few minutes of operation and does not indicate a malfunction in the heater.

4 Operation and function

Description of functions

Switching on

When the heater is switched on, the control lamp in the control element lights up.

The glow plug is switched on and the fan starts at low speed.

Please note!

If there is still too much residual heat in the heat exchanger from when the heater was last used, firstly only the fan starts up (cold blowing).

Once the residual heat has been cleared, the heater starts.

Starting Airtronic

After approx. 65 seconds the fuel supply starts and the fuel / air mixture in the combustion chamber ignites.

Once the combined sensor (flame sensor) has detected the flame, the glow plug is switched off after 60 seconds. The heater is now in standard operation.

Starting Airtronic M

After approx. 60 seconds the fuel supply starts and the fuel / air mixture in the combustion chamber ignites.

After the flame sensor has detected the flame, the glow plug is switched off after approx. 90 sec. The heater is now in standard operation.

After another 120 seconds, the heater has reached the "POWER" stage (maximum fuel quantity, maximum fan speed).

Temperature selection with the control element

The control can be used to preselect an interior temperature.

The resulting temperature can be within the range of +10 °C to +30 °C and depends on the selected heater, on the size of the space to be heated and on the prevailing outdoor temperature.

The setting to be selected at the control is an empirical value.

Control in the heating mode

During the heating mode, the room temperature or the temperature of the sucked in heating air is constantly measured.

If the temperature is higher than the temperature selected on the control element, the heater starts to regulate its output. There are 4 control stages so that the outflow of heat produced by the heater can be adjusted finely to the heating requirements. Fan speed and fuel quantity correspond to the particular control stage.

If the set temperature is still exceeded in the smallest control stage, the heater goes to the "OFF" stage with the fan running on for approx. 4 minutes to cool off. Then the fan continues at minimum speed (circulation mode) or is switched off (fresh air mode) until the heater is started again.

Ventilating mode

In the ventilating mode, first the changeover switch "heating / venting" has to be activated and then the heater is switched on.

Switching off

When the heater is switched off, the control lamp goes off and the fuel supply is switched off.

The fan runs on for approx. 4 minutes to cool down.

While the fan is running on, the glow plug is switched on for approx. 40 seconds to clean.

Special case:

If no fuel has been supplied or if the heater is in the "OFF" stage until it is switched off, the heater is stopped without any after running.



4 Operation and function

Control and safety devices

- If the heater does not ignite within 90 seconds after starting the fuel pump, the start is repeated. If the heater still does not ignite after another 90 seconds of pumping fuel, the heater is switched off, i.e. the fuel supply is off and the fan runs on for approx. 4 minutes.
- If the flame goes off by itself during operation, the heater is restarted. If the heater does not ignite within 90 seconds after the fuel pump has started, or ignites and goes off again within 15 minutes, the heater is switched off, i.e. the fuel supply is off and the fan runs on for approx. 4 minutes. This status can be remedied by briefly switching off and on again. Do not repeat the switching off/on routine more than twice.
- In the case of overheating, the combined sensor (flame sensor / overheating sensor) triggers, the fuel supply is interrupted and the heater switched off. Once the cause of the overheating has been eliminated, the heater can be re-started by switching off and on again.
- If the lower or upper voltage limit is reached, the heater is switched off after 20 seconds.
- The heater does not start up when the glow plug is defect or when the electric lead to the dosing pump is interrupted.
- If the combined sensor (flame sensor / overheating sensor) is defect or the electric lead interrupted, the heater starts up and is then switched off again during the start phase.
- The speed of the fan motor is monitored continuously. If the fan motor does not start up or if the speed deviates by more than 10%, the heater is switched off after 30 sec.
- When the heater is switched off, the glow plug is switched on for 40 seconds (after-glowing) while the fan runs on to clean off any combustion residues.

Please note!

Do not switch the heater off and on again more than twice.

Forced shutdown in ADR mode (only for diesel heaters 24 volt)

In vehicles for the transport of dangerous goods (e.g. tanker trucks), the heater must be switched off before the truck drives into a danger area (refinery, fuel service station, etc.).

Failure to comply results in the heater switching off automatically when:

- The vehicle engine is switched off.
- An additional unit is started up (e.g. auxiliary drive for unloading pump etc.).

The fan then runs on for max. 40 seconds.

Emergency shutdown – EMERGENCY OFF

If an emergency shutdown – EMERGENCY OFF – is necessary during operation, proceed as follows:

- Switch the heater off with the control or
- pull the fuse out or
- disconnect the heater from the battery.

5 Electrical system

Heater wiring

The electronic control box is integrated in the heater, which considerably simplifies the wiring required during installation.



Caution!

Safety instructions for wiring the heater!

The heater is to be connected up electrically according to the EMC directives.

EMC can be affected if the heater is not connected up correctly. For this reason, comply with the following instructions:

- Ensure that the insulation of electrical cables is not damaged. Avoid: chafing, kinking, jamming or exposure to heat.
- In waterproof connectors, seal any connector chambers not in use with filler plugs to ensure they are dirt-proof and water-proof.
- Electrical connections and ground connections must be free of corrosion and firmly connected.
- Lubricate connections and ground connections outside the heater interior with contact grease.

Please note!

Comply with the following when wiring the heater and the control element:

- With the appropriate electrical wiring, the heater fulfils the ADR regulations; please refer to the circuit diagrams at the end of this document.
- Electrical leads, switchgear and controllers must be arranged in the vehicle so that they can function perfectly under normal operating conditions (e.g. heat exposure, moisture etc.).
- The following cable cross sections are to be used between the battery and heater. This ensures that the max. tolerable voltage loss in the cables does not exceed 0.5 V for 12 V or 1 V for 24 V rated voltage. Cable cross sections for a cable length of (plus cable + minus cable):
 - up to 5 m = cable cross section 4 mm²
 - from 5 to 8 m = cable cross section 6 mm²
- If the plus cable is to be connected to the fuse box (e.g. terminal 30), the vehicle cable from the battery to the fuse box must be included in rating the overall cable length and possibly re-dimensioned if necessary.
- Insulate unused cable ends.



5 Electrical system

Parts list for the circuit diagrams Airtronic / Airtronic M and Airtronic / Airtronic M – ADR mode

-A1	Airtronic / Airtronic M control box
-A30	Fuse holder, 3 pin
-B1	Control sensor, internal
-B6	Flame and overheating sensor
-F1	Fuse 12 V = 20 A / 24 V = 10 A
-M4	Burner motor
-R1	Glow plug
-Y1	Fuel metering pump

Optional

- b Activation of vehicle blower and / or separate fresh air fan

Please note!

- The plus signal is only applied in „Low“ control stage (PIN 16, plus signal for relay, $I_{max} = 200 \text{ mA}$)

ADR function

Wiring for ADR mode (dangerous goods in utility or commercial vehicles, e.g. fuel tanker) - wire yourself according to vehicle circumstances

- | | |
|---|--------------------------|
| m | Battery isolating switch |
| n | Auxiliary drive NA+ |
| o | Generator D+ |

Please note!

- It must be ensured that if the battery isolating switch is pressed due to EMERGENCY STOP, all the heater's electric circuits are disconnected from the battery immediately (without any consideration of the heater's status).
- If the battery isolating switch is pressed to disconnect the battery from all electric circuits, the heater must be switched off first and if applicable you must wait until the heater's afterrun has finished.

- a to the heater
c to the control unit
x Insulate and tie back any cable ends that are not needed.

Please note!

Circuit diagram for Airtronic / Airtronic M see Page 34 and 35.

Circuit diagram for Airtronic / Airtronic M in ADR mode – see also Page 36.

For circuit diagrams for other control units, e.g. EasyStart T, R and R+, refer to the installation instructions of the control unit concerned.

5 Electrical system

Airtronic / Airtronic M

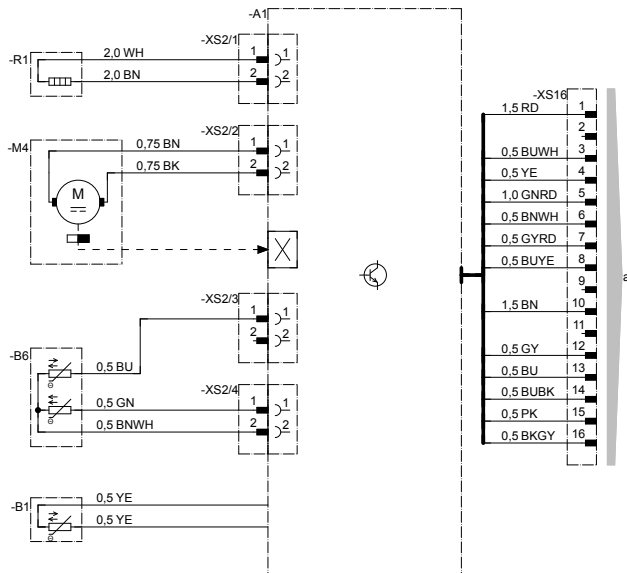
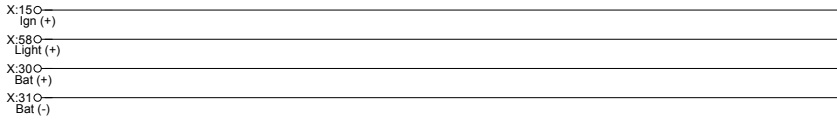

5 Electrical system



Airtronic / Airtronic M

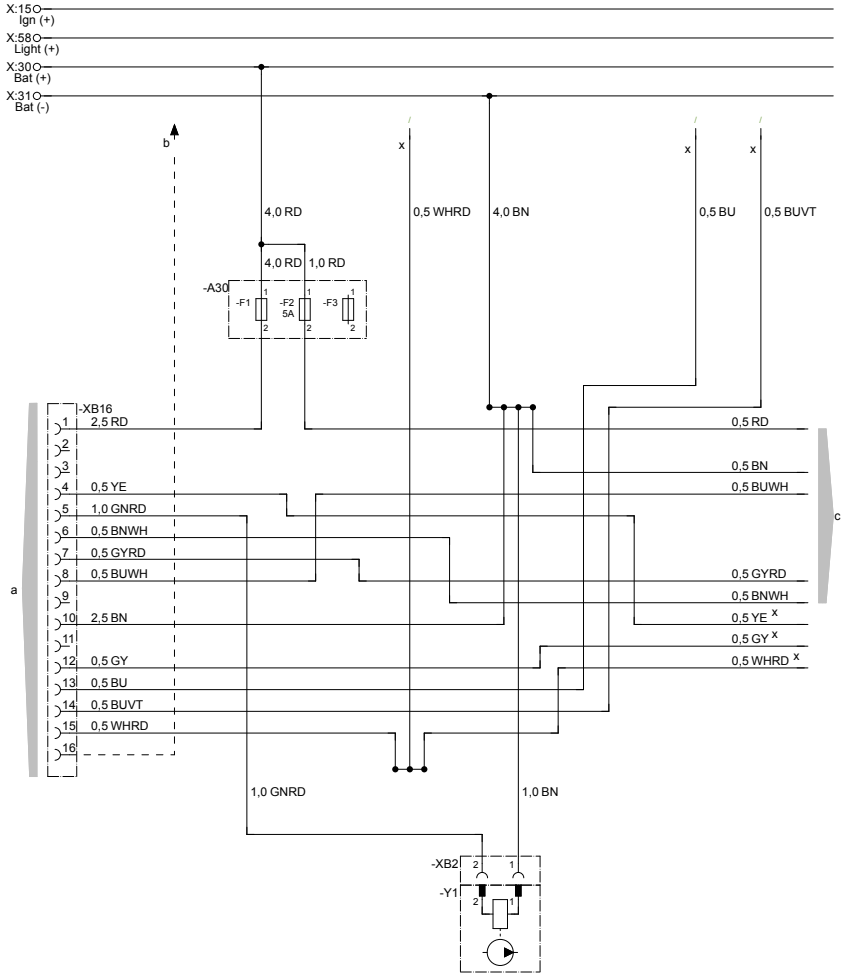

5 Electrical system

Circuit diagram Airtronic / Airtronic M – ADR mode

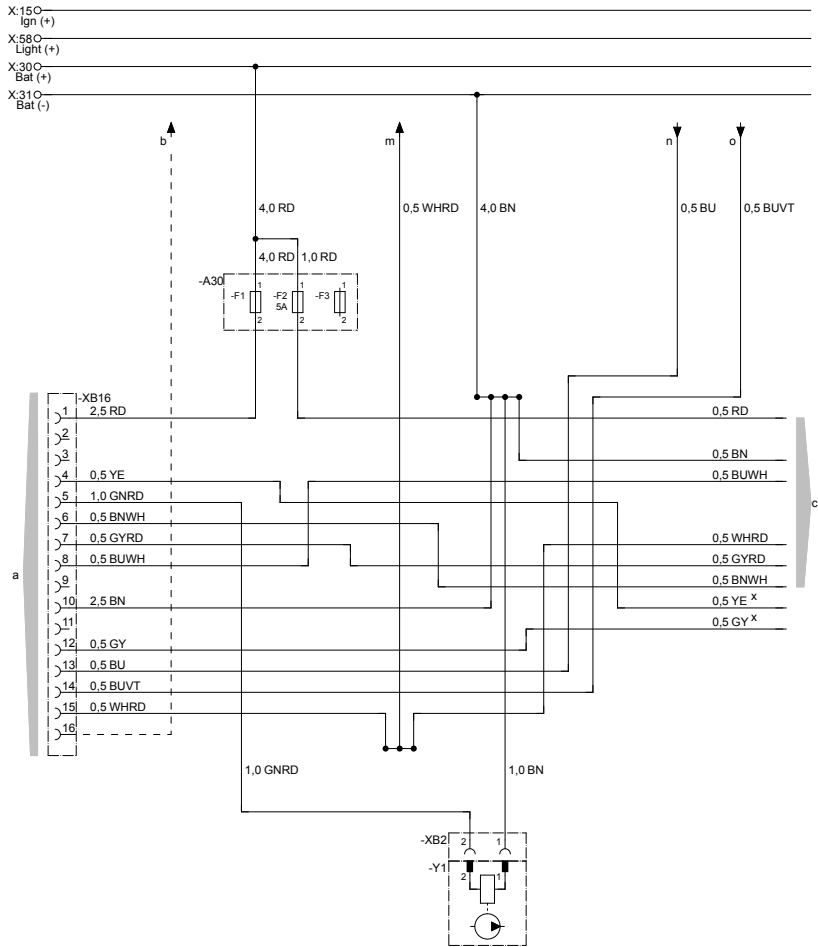



5 Electrical system

Circuit diagram EasyStart Timer

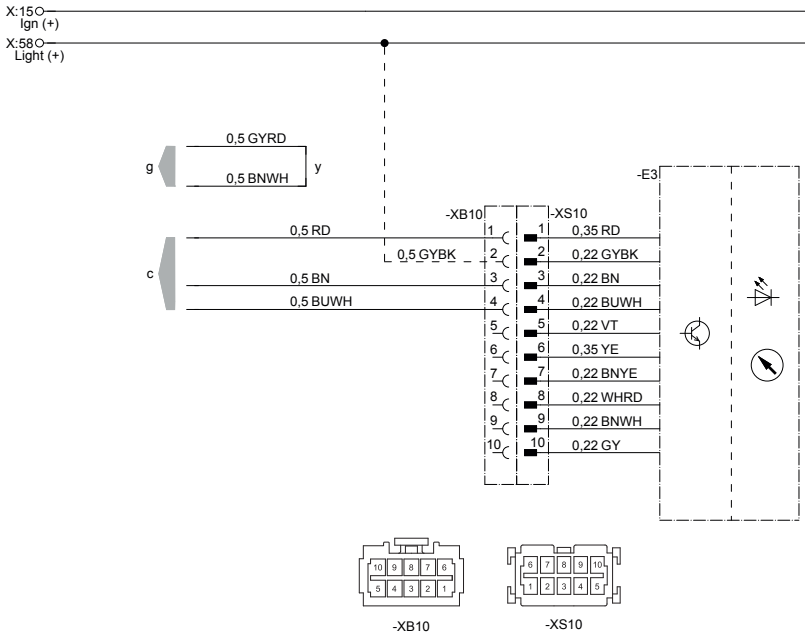

22 1000 34 97 20

Cable colours

E3 EasyStart Timer Timer
c to the heater
g to the heater
y Connect cables and insulate

RD = red
BU = blue
WH = white
GY = grey
YE = yellow

VT = violet
BK = black
GN = green
BN = brown

Please note!

- For heater circuit diagrams see page 34, 35 and 36.
- Further circuit diagrams for the EasyStart Timer are printed in the Installation Instructions Plus, these are available to view and download from the Service Portal.

5 Electrical system

Circuit diagram EasyStart Remote+

X:15 O
Ign (+)

X:58 O
Light (+)

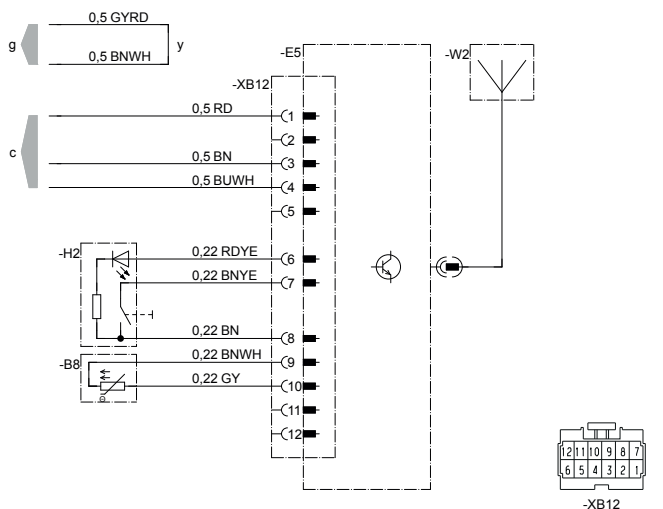

25 2361 00 97 01 C

Cable colours

B8 Room temperature sensor
E5 EasyStart Remote+ radio remote control
H2 Button
W2 Antenna
c to the heater
g to the heater
y Connect cables and insulate

RD = red
BU = blue
WH = white
GY = grey
YE = yellow
VT = violet
BK = black
GN = green
BN = brown

Please note!

- For heater circuit diagrams see page 34 and 35.
- Further circuit diagrams for the EasyStart Remote+ are printed in the Installation Instructions Plus, these are available to view and download from the Service Portal.



5 Electrical system

Circuit diagram EasyStart Select

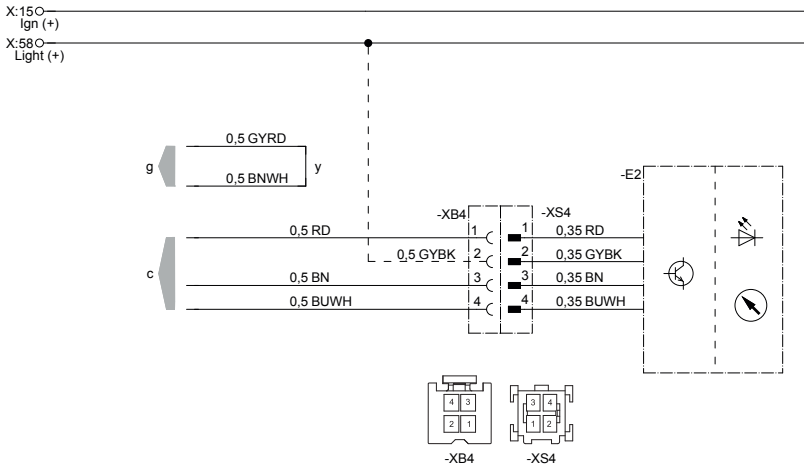

25 2361 00 97 05 B

E2 EasyStart Select
 c to the heater
 g to the heater
 y Connect cables and insulate

Cable colours

RD = red
 BU = blue
 WH = white
 GY = grey
 YE = yellow
 VT = violet
 BK = black
 GN = green
 BN = brown

Please note!

- For heater circuit diagrams see page 34 and 35.
- Further circuit diagrams for the EasyStart Select are printed in the Installation Instructions Plus, these are available to view and download from the Service Portal.

5 Electrical system

Circuit diagram EasyStart Call

X:15 ○ Ign (+)
 X:58 ○ Light (+)

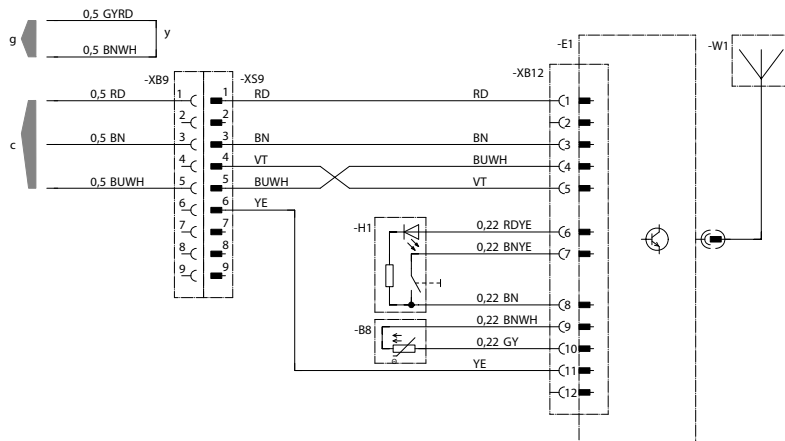

25 2361 00 97 02 B

Cable colours

B8 Room temperature sensor
 E1 EasyStart Call radio remote control
 H1 EasyStart Call button
 W1 EasyStart Call antenna
 c to the heater
 g to the heater
 y Connect cables and insulate

RD = red
 BU = blue
 WH = white
 GY = grey
 YE = yellow
 VT = violet
 BK = black
 GN = green
 BN = brown

Please note!

- For heater circuit diagrams see page 34 and 35.
- Further circuit diagrams for the EasyStart Call are printed in the Installation Instructions Plus, these are available to view and download from the Service Portal.



In case of faults, please check the following points

- If the heater does not start after being switched on:
 - Switch the heater off and on again.
- If the heater still does not start, check whether:
 - There is fuel in the tank?
 - The fuses are OK?
 - The electrical cables, connections etc. are OK?
 - Anything is clogging the combustion air supply or exhaust system?

Troubleshooting

If the heater remains faulty even after these points have been checked, or another malfunction occurs in your heater, please contact:

- For installation ex works, your contract workshop.
- For subsequent installation, the workshop who installed your heater.

Please note!

Please note that warranty claims can become void if the heater is changed by a third party or by this installation of third party parts.

Maintenance instructions

- Switch the heater on once a month for about 10 minutes, even outside the heating period.
- Before the heating period starts, the heater should undergo a trial run. If persistent extreme smoke develops, unusual burning noises or a clear fuel smell can be perceived or if electric / electronic parts heat up, the heater must be switched off and put out of service by removing the fuse. In this case, the heater should not be started up again until it has been checked by qualified staff who have been trained on Eberspächer heaters.
- Check the openings of the combustion air supply and exhaust system after longer standstill periods, clean if necessary!

Service

If you have any technical queries or problems with your pre-heater, dial the following service phone number:

Hotline
Phone. 0800 / 12 34 300

Fax hotline
Fax 01805 / 26 26 24

Outside of Germany, please contact the respective national Eberspächer service agent.

7 Environment

Certification

The high quality of Eberspächer's products is the key to our success.

To guarantee this quality, we have organised all work processes in the company along the lines of quality management (QM).

Even so, we still pursue a large number of activities for continuous improvement of product quality in order to keep pace with the similarly constantly growing requirements made by our customers.

All the steps necessary for quality assurance are stipulated in international standards.

This quality is to be considered in a total sense.

It affects products, procedures and customer / supplier relationships.

Officially approved public experts assess the system and the corresponding certification company awards a certificate.

Eberspächer has already qualified for the following standards:

**Quality management as per
DIN EN ISO 9001:2000 and ISO/TS 16949:1999**

**Environment management system as per
DIN EN ISO 14001:1996**

Disposal

Disposal of materials

Old devices, defect components and packaging material can all be separated and sorted into pure-grade fractions so that all parts can be disposed of as required in an environment-friendly manner or recycled where applicable.

Electric motors, controllers and sensors (e.g. temperature sensors) are deemed to be "electronic scrap".

Dismantling the heater

The heater is dismantled according to the repair stages in the current troubleshooting / repair instructions.

Packaging

The packaging of the heater can be kept in case it has to be sent back.

EU Declaration of Conformity

The manufacturer:

**Eberspächer Climate Control Systems
GmbH & Co. KG.**

Address:
Eberspächerstraße 24
D-73730 Esslingen

herewith declares that the following product:

Product name	Vehicle heater	
Type	Airtronic	Airtronic M
Version	D2	B3 Plus B4 D3 D4 D4 Plus

fulfils the requirements of the following EC Directives:

- Heating systems directive 2001/56/EC
Revision status 2006/119/EC
- Radio interference (EMC) of vehicles 72/245/EEC,
Revision status 2006/28/EC
- Heater control ECE-R 122,
Revision status 00
- EMC of vehicles ECE-R 10,
Revision status 03

The following EC Directives and UN regulations have been used to assess the product:

2001/56/EC; 72/245/EEC; ECE-R 122; ECE-R 10



8 Lists

List of key words A – Z

Keyword	Page	Keyword	Page
A		I	
Accident prevention	7	Introduction	4, 5
ADR	16	Installation	16 – 28
Altitude	29	Installation area	16, 17
Ambient temperature	12 – 14	Interference suppression class	12 – 14
		Initial commissioning	29
C		Installation location	16, 17
Cable harness connection	18	Installation position	18
Certificates	42	Information	4
Circuit diagrams	34 – 40	Important instructions	29
Combustion air system	23		
Control devices	31	L	
Control in heating mode	30	List of abbreviations	44
Contents	2		
		M	
D		Maintenance	41
Dangerous goods	16, 31	Main dimensions	15
Declaration of conformity	42		
Description of functions	30	N	
Disposal	42	Nameplate	20
Dosing pump	24 – 27		
		O	
E		Operation	29
Electronic components	33, 36	Operating instructions	29
Emergency off	31		
Environment management	42	P	
EU Declaration of Conformity	42	Picture symbols	4
Exhaust system	22	Power consumption	12 – 14
		Pressure height	27
F		Pressure side	25, 26
Faults	46	Presentation	4
Fastening	19	Purpose	4
Fan operation	30		
Forced shut-down	31	R	
Formation of air bubbles	24	Rated voltage	12 – 14
Fuel supply	5, 24 – 28	Regulations	5, 6
Fuel consumption	12 – 14		
Fuel quality	28	S	
		Safety devices	31
H		Safety check (before starting)	29
Heat flow	12 – 14	Scope of supply	8 – 11
Hotline	41	Storage temperature	12 – 14
		Statutory regulations	5, 6
		Start procedure	30
		Suction height	27
		Switching on	30
		Switching off	30

8 Lists

List of key words A – Z

Keyword	Page
T	
Technical data	12 – 14
Temperature selection	30
Test symbol	5
Text structure	4
T-piece	25
Transport	16
Troubleshooting	41
U	
Use	4
V	
Voltage	12 – 14
Voltage limit	12 – 14
W	
Weight	12 – 14
Wiring	32

List of abbreviations

ADR

European agreement about the international transport of dangerous goods on the road.

EC Type approval

Permit awarded by the Federal Vehicle Office for the production of a heater for installation in motorised vehicles.

EMC directive

Electromagnetic compatibility.

JE partner

Eberspächer partner.

FAME

Biodiesel according to DIN V 14 214.

www.eberspaecher.com

Eberspächer Climate Control Systems
GmbH & Co. KG
Eberspächerstraße 24
D-73730 Esslingen
Telefon 0800 1234300
Telefax 01805 262624
info@eberspaecher.com
www.eberspaecher.com



Eberspächer®