

# COMPLETE HEATING SYSTEMS FROM ESPAR



APRIL 2013

A WORLD OF COMFORT



## QUICK-REFERENCE GUIDE



Espar heaters have become one of the most popular money saving products available in the heavy-duty truck market today. Typical savings using an Airtronic D2 can be as much as \$6,000 per unit per year based on current fuel prices. Below you will find the most popular selling kit numbers for our air and coolant heater models. For a detailed listing of our complete product line including heater kits, accessories and controllers for heavy truck, light truck, school bus, industrial and oilfield markets please see the following pages.

All the heater products mentioned on the Quick-Reference pages are EPA Verified and CARB compliant for worry-free operation anywhere in the United States.

### AIRTRONIC D2

#### DIESEL AIR HEATER / TRUCK BUNK HEATER

The Airtronic D2 puts out 7,500 BTU of clean comfortable heat and is ideal for bunk heating in all makes of heavy-duty trucks. It has a higher heat output than competitive models and is equipped with a standard fan-mode for nights when air circulation is preferred instead of heating.

The most popular Airtronic D2 kit is listed below. It comes with everything needed for installation including: Heater, Digi-Max Controller, fuel system, mounting hardware kit and all ducting.

#### **Airtronic D2 – Truck Kit with Digi-Max Controller 20 2820 69 0263**

The Digi-Max Controller is the latest generation of heater controls and is an Espar exclusive. It provides an easy to set digital display, an onboard ambient air temperature sensor, an adjustable auto shutoff, adjustable low voltage protection, records maintenance hours and displays trouble shooting tips for fault codes displayed.

### HYDRONIC D5

#### DIESEL COOLANT HEATER / ENGINE PRE-HEATER

The Hydronic D5 generates 17,500 BTU of heat for quickly pre-heating your trucks engine on those cold winter mornings. It is typically timer operated and can be programmed to begin work up to an hour before you are ready to start work, pre-heating the entire cooling system and providing an easier start along with instant cab heat and window defrosting. Manual start and stop is also available.

The most popular Hydronic D5 kits are listed below. One comes in a rugged-duty box for protection and long-life in external mountings. The kits come with: Heater, 7-day timer, fuel system and necessary components for a typical truck installation.

**Hydronic D5 – Boxed Unit w/ 7 Day Timer 25 2822 19 0541**

**Hydronic D5 – Unboxed w/ 7 Day Timer 25 2822 19 0521**

Use of an engine pre-heater reduces cold start wear on internal components, reduces stress on the starting/cranking system, and can help extend DOC/DPF regen and replacement cycles by reducing cold-start white smoke.

### COMBO KITS

#### DIESEL AIR AND COOLANT HEATER PACKAGES

In some markets the weather is cold enough that drivers may prefer to run the Airtronic D2 for cab heat and the Hydronic D5 for engine pre-heating. In this case the driver will typically use the D2 for a comfortable night's sleep and turn the engine pre-heater on about an hour before getting up – ensuring a reliable engine start and quicker start of operation. Combo Kits are specially priced and include both the D2 with Mini-Controller and D5 with 7-Day timer along with the mounting components mentioned above.

The most popular numbers for combo kits with Hydronic D5 w/7-Day Timer & Airtronic D2 w/Mini-Controller are:

**Airtronic D2 with Mini controller and Hydronic D5 with 7 day timer 20 2812 15 2056**

**Airtronic D2 with Mini controller and Boxed Hydronic D5 with 7 day timer 20 2812 15 2057**

### HEATER INSTALLATION TIPS -

For a time saving video showing a typical Class 8 truck installation for each of these products please visit the Espar website at [www.espar.com](http://www.espar.com) and see the links along the right side of the main Downloads page. See your local dealer for special pricing on quantity purchases of money-saving Espar heaters.

## QUICK-REFERENCE GUIDE

### INTRODUCTION PAGE

On the following pages you will find the entire offering of Espar heaters, heater kits, control options and accessories. Below are some tips on how to best choose the products you are looking for.

**PAGE LAYOUT** – The Product Catalog is a complete listing of the products we sell.

In the heater section, you can trace the heater you are considering straight across to the dots in the columns on the right side of the page. These columns have a header row showing the items offered - with the dots indicating which of them actually come in the kit being selected. In the accessory section, you trace the accessory across to the dots on the far right to see what heaters that component is used with.

**HEATER CHOICES** – Our heaters come in both 12 and 24 Volt offerings and in Gasoline (B prefix) and Diesel (D prefix) models. When selecting a heater model, be sure to begin with the right voltage and fuel type for your application. The “Basic” heaters shown are just that, a bare heater, and are usually used as replacements. If a heater price seems too low, compared to other models, be sure it’s not a basic kit.

- **RECOMMENDED** – There are a variety of kits and components in the catalog that may look similar. When more than one item is listed, look for the **RECOMMENDED** label. This indicates that item is one of the more commonly sold products of those that are listed. However, we want to make sure you get the right pieces for the job so if you are in doubt please don’t hesitate to call your local regional sales manager or our tech service department (800-387-4800) for assistance.

- **EMISSIONS** – Espar offers more EPA Verified / CARB Compliant heater choices than any other manufacturer. Look for the EPA label when selecting a heater for specific applications.
- **AIRTRONIC HEATER KITS** – Unless specified otherwise these kits are usually sold as complete with installation components. The variables are usually limited to multiple controller and fuel pickup choices. These are all noted in the kit description and in the columns on the right side of the page.
- **HYDRONIC HEATER KITS** – Unless otherwise note these units are typically sold ala-carte – with the heater kit, timer/controller and even installation kits purchased separately to provide maximum installation flexibility. Always check the description and the kit component listing in the columns on the right side of the page.
- **CONTROLLERS** – Espar offers a variety of controllers for almost every heater model and application combination. The most popular air heater controller is the Digi-Max Controller with the 7-Day (truck) and Programmable (school bus) timers the most popular for coolant heaters. School bus and/or industrial applications using coolant heaters may also choose to include the Multi-Function Switch.



## QUICK-REFERENCE GUIDE

### FUEL PICK-UP / FMP OPTIONS:

Espar makes a number of fuel pickup and fuel pump mounting options to help streamline installations. Below you will find a summary of some of those choices.

- **UNIVERSAL PICKUP** – Unless designated otherwise, Espar heater kits that show to have a fuel pickup tube come with our “Universal Pickup.” This offers the flexibility of a typical cut-the-tank installation or the ability to remove the center NPT fitting for installation in a NPT port on the fuel tank (if available).
- **NO PICKUP** - Kits marked “No Pickup” do not have a fuel pickup tube. A variety of pickup tubes, including those for specialty use or to be used with NPT compression fittings, are located in the fuel section. Choosing the right fuel pickup can save time and provide a custom installation.
- **VENT PICKUP** – Kits marked “Vent Pickup” come with a fuel pickup tube made for installation using the trucks fuel system vent port.
- **EXTERNAL / INTERNAL FMP** – The Espar FMP’s, or fuel metering pumps, can pull fuel 6’ and push it approximately 20’, thus the FMP needs to be located within 6’ of the primary fuel source. Coolant heater kits with an External FMP typically are used when the heater is located more than 6’ from the fuel source.

### BOXED:

Kits marked “Boxed” means the heater comes installed in a rugged metal enclosure for protection and long-life. The box is usually frame rail mounted but can also be used in a variety of industrial or heavy equipment applications. Espar’s large coolant heater models use a heavy-duty box manufactured by Arctic Fox and carries a direct replacement footprint for many legacy heaters in the field.

### SPECIALTY KITS:

Espar manufactures several specialty kits to provide the best heater life and maximum levels of reliability and safety for end-users.

- **HIGH ALTITUDE** – Espar provides a number of options to get the best performance from units operating at higher altitudes where the air is thin and heaters tend to run rich. These include: A full heater truck kit - OR - a fuel metering pump adjusted for full-time high altitude operation or a plug-and-play module for leaning out fuel delivery. The latter two can be used to modify a standard heater kit for HA operation. All are geared toward heaters in applications spending longer amounts of time operating above 4,900 ft.

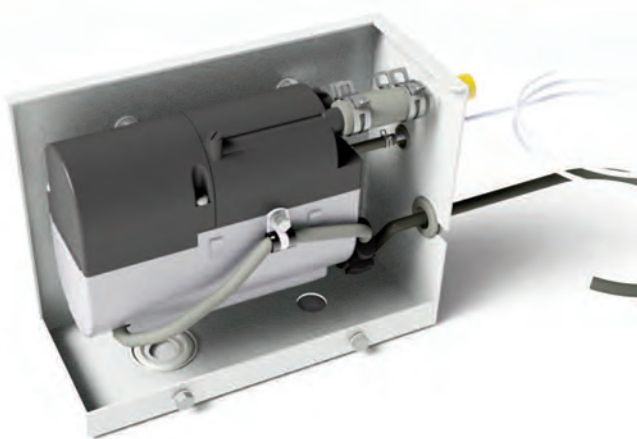

# CONTENTS

CHAPTER	TITLE	CONTENT	PAGE
I	Contents	Table of Contents	5
	HEATERS AND KIT BREAKDOWN (Scope of Delivery)		
1	AIR HEATERS	<i>AIRTRONIC D2, Truck Kits</i>	6
		<i>AIRTRONIC D2, High altitude kits</i>	6
		<i>AIRTRONIC D2, Spare parts</i>	7
		<i>AIRTRONIC D4 / B4</i>	8
		<i>AIRTRONIC D4 / B4, Spare parts</i>	9
		<i>B1LC compact</i>	10
		<i>AIRTRONIC B / D5</i>	11
		<i>D8LC</i>	12
2	COOLANT HEATERS	<i>HYDRONIC B / D5 SC</i>	14
		<i>HYDRONIC B / D5 SC, Spare parts</i>	15
		<i>Pick-Up Truck Kits (After Market)</i>	16
		<i>HYDRONIC II B5E / HYDRONIC II D5E</i>	17
		<i>HYDRONIC B / D5 S</i>	18
		<i>COMBO KIT - AIRTRONIC D2 and HYDRONIC D5 Truck Kit</i>	19
		<i>COMBO KIT - AIRTRONIC D2 and HYDRONIC D5 Boxed Truck Kit</i>	19
		<i>COMBO KIT - AIRTRONIC D4 and HYDRONIC D5 Truck Kit</i>	20
		<i>HYDRONIC 10 / M, Spare parts</i>	22
		<i>HYDRONIC M-II, Spare parts</i>	23
		<i>E-Guardian</i>	24
		<i>HYDRONIC L-II / 16 / 24 / 30 / 35</i>	25
		<i>HYDRONIC L-II Boxed Heater Kits</i>	26
3	Accessories Parts Guide	<i>Timers and Controlers Table</i>	28
		<i>Control Options and Timers</i>	29-31
		<i>Testers, Adapters and Special Tools</i>	32-33
		<i>Fuel System</i>	34-37
		<i>Mounting Parts</i>	38-40
		<i>Bulk Wiring</i>	41
		<i>Fuse Holders, Fuses and Breakers</i>	42-43
		<i>Terminals and Connectors</i>	44-47
		<i>Power Converters 12V to 24V</i>	48
		<i>Exhaust</i>	50-53
		<i>Ducting</i>	54-60
		<i>Coolant Pumps</i>	61
		<i>Plumbing</i>	62-65
		<i>Fuel System Guide</i>	66
		<i>Ducting Rating Guide</i>	67-79

# AIRTRONIC 2 DIESEL AIR - 7,500 BTU

## SCOPE OF DELIVERY

DESCRIPTION	PART NUMBER	Heater	Harness	Fuel System	Ducting	Mounting Bracket	Control Options / Timers	Fuel Pickup Pipe	Hardware Kit	Exhaust Pipe	Intake Pipe	Manuals
<b>AIRTRONIC D2 - Carb Approved</b>												
Basic Heater 12V with fuel pump - No installation parts	25 2069 05 0000	•										•
Basic Heater 24V with fuel pump - No installation parts	25 2070 05 0000	•										•
JE Universal Installation Kit 12V and 24V	25 2069 80 0000		•	•	•				•	•	•	
Espar Universal Installation Kit 12V and 24V	20 2820 69 0280		•	•	•			•	•	•	•	
<b>AIRTRONIC D2 - Carb Approved HEATER WITH INSTALLATION KIT</b>												
Truck Kit 12V w/ Digi-Max Controller w/ Universal pick up <span style="background-color: yellow;">RECOMMENDED</span>	20 2820 69 0263	•	•	•	•	•	•	•	•	•	•	•
Truck Kit 12V w/ Digi-Max Controller, no fuel pick-up pipe	20 2820 69 0261	•	•	•	•	•	•		•	•	•	•
Truck Kit 12V w/ Thermostat w/ Universal pick up pipe	20 2820 69 0281	•	•	•	•	•	•	•	•	•	•	•
Truck Kit 12V w/ Thermostat w/ 90° outlet hood w/Universal pick up pipe	20 2820 69 0284	•	•	•	•	•	•	•	•	•	•	•
Truck Kit 12V w/ Mini-Controller w/Universal pick up pipe	20 2820 69 0285	•	•	•	•	•	•	•	•	•	•	•
Truck Kit 12V w/ 7-Day Timer w/Universal pick up pipe	20 2820 69 0286	•	•	•	•	•	•	•	•	•	•	•
Truck Kit 12V w/ 90° outlet hood, no fuel pick up pipe	20 2820 69 0288	•	•	•	•	•			•	•	•	•
Truck Kit 12V w/ Mini-Controller w/ pick-up pipe for vent fitting	20 2820 69 0291	•	•	•	•	•	•	•	•	•	•	•
Truck Kit 12V w/ Thermostat, no fuel pick-up pipe	20 2820 69 0295	•	•	•	•	•	•		•	•	•	•
Truck Kit 12V w/ Mini-Controller, no fuel pick-up pipe	20 2820 69 0296	•	•	•	•	•	•		•	•	•	•
Truck Kit 24V w/ Thermostat w/ Universal pick up pipe	20 2820 70 0281	•	•	•	•	•	•	•	•	•	•	•
Truck Kit 24V w/ Mini-Controller w/ Universal pick up pipe	20 2820 70 0285	•	•	•	•	•	•	•	•	•	•	•
<b>AIRTRONIC D2 CAMPER DIESEL - Carb Approved</b>												
Camper Heater 12V with fuel pump - (Limited in stock)	25 2326 05 0000	•										•
<b>HIGH ALTITUDE COMPENSATION KITS - FOR UNRESTRICTED HEATER USE OVER 5000 FEET</b>												
High altitude fuel pump	24 0222 00 00 00											
High altitude compensator - Can not be used with heaters that have "H-Kit" on factory label	20 2900 70 00 07											
High altitude sensor - Only use with heaters that show "H-Kit" on their factory label	22 1000 33 22 00											
<b>AIRTRONIC TRAINING KIT</b>												
Airtronic D2 - with carrying case and mini controller	20 2820 69 02 83											

**Hardware Kit INCLUDES:**

- Fuel Clamps
- Nuts
- Cable Ties
- Grommets
- Exhaust Clamps
- Mounting Screws

- Ducting Clamps
- Washers
- Routing Clamps

- End Caps
- Exhaust Brackets

**Fuel System INCLUDES:**

- Clamps
- 5mm Fuel Line
- Plastic Fuel Line
- 3.5mm Fuel Line

Refer to the Accessories Section for ducting components and additional accessories.  
For the addition of engine preheat, refer to the Combo Truck Kits Section.

1  
2  
3

**AIRTRONIC 2 Diesel** DIESEL AIR - 7,500 BTU

**Spare parts**

25 2069 05 00 00

The parts shown are for the most common 12V model heater of this type - model #-, top right corner

DESCRIPTION	PART NUMBER
Blower Unit	25 2069 99 2000
Control Unit	22 5101 00 3001
Glow Pin	25 2069 01 1300
Atomizer Screen	25 2069 10 0102
Combo-Sensor (Flame / Overheat)	25 2069 01 0200
Fuel Metering Pump	22 4519 01 0000
Flexible Exhaust Tube 24mm	360 61 557
Fuse 20A Blade Type	5670055
Fuse 5A	204 00 079
Digi-Max Controller	20 2800 70 1500
Thermostat	5670097
Fuel Pump Screen	20 1312 00 00 06



1  
2  
3

# AIRTRONIC 4 DIESEL AIR HEATER - 13,600 BTU

## SCOPE OF DELIVERY

DESCRIPTION	PART NUMBER	Heater	Harness	Fuel System	Ducting	Mounting Bracket	Control Options / Timers	Fuel Pickup Pipe	Hardware Kit	Exhaust Pipe	Intake Pipe	Manuals
<b>AIRTRONIC B4 GASOLINE</b>												
Gasoline Basic Heater 12V with fuel pump	20 1812 05 00 00	•										•
<b>AIRTRONIC D4 DIESEL - Carb Approved</b>												
Basic Heater 12V with fuel pump - No installation parts	25 2113 05 00 00	•										•
Basic Heater 24V with fuel pump - No installation parts	25 2114 05 00 00	•										•
<b>Universal Install Kits</b>												
JE Universal Installation Kit 12V and 24V	25 2113 80 00 00		•	•	•				•	•	•	•
Espar Universal Installation Kit 12V and 24V <span style="background-color: yellow;">RECOMMENDED</span>	20 2821 13 04 80		•	•	•			•	•	•	•	•
Espar Universal Installation Kit 12V and 24V (no fuel pick-up)	20 2821 13 04 30		•	•	•				•	•	•	•
<b>AIRTRONIC D4 TRUCK KITS - Carb Approved HEATER WITH INSTALLATION KIT</b>												
Truck Kit 12V with Digi-Max Controller <span style="background-color: yellow;">RECOMMENDED</span>	20 2821 13 04 23	•	•	•	•	•	•	•	•	•	•	•
Truck Kit 12V w/Thermostat	20 2821 13 04 81	•	•	•	•	•	•	•	•	•	•	•
Truck Kit 12V w/Mini-Controller	20 2821 13 04 85	•	•	•	•	•	•	•	•	•	•	•
Truck Kit 24V w/Mini-Controller	20 2821 14 04 85	•	•	•	•	•	•	•	•	•	•	•
<b>AIRTRONIC B4 GASOLINE TRUCK KIT</b>												
12v with mini controller	20 2818 12 0485	•	•	•	•	•	•	•	•	•	•	•
<b>AIRTRONIC 4 CARGO KITS</b>												
Cargo Kit 12V with Thermostat	20 2900 00 04 01		•	•	•	x	•	•	•	■	•	•

x = cargo bracket  
 ■ = exhaust with plate

**Hardware Kit INCLUDES:**

- Fuel Clamps
- Nuts
- Cable Ties
- Grommets
- Exhaust Clamps
- Mounting Screws
- Ducting Clamps
- Washers
- Routing Clamps
- End Caps
- Exhaust Brackets

**Fuel System INCLUDES:**

- Clamps
- 5mm Fuel Line
- Plastic Fuel Line
- 3.5mm Fuel Line

Refer to the Accessories Section for ducting components and additional accessories.  
 For the addition of engine preheat, refer to the Combo Truck Kits Section.

1  
2  
3

**AIRTRONIC 4** DIESEL AIR HEATER - 13,600 BTU

**Spare parts**

25 2113 05 00 00

The parts shown are for the most common 12V model heater of this type - model #-, top right corner

DESCRIPTION	PART NUMBER
Blower Unit	25 2113 99 2000
Control Unit	22 5101 00 3005
Glow Pin	25 2069 01 1300
Atomizer Screen	25 2069 10 0102
Combo-Sensor (Flame / Overheat)	25 2069 01 0200
Fuel Metering Pump	22 4519 01 0000
Flexible Exhaust Tube, 24mm	360 61 550
Fuse 20A Blade Type	5670055
Fuse 5A	204 00 079
Digi-Max Controller	20 2800 70 1500
Thermostat	5670097
Fuel Pump Screen	20 1312 00 00 06



## B1LC compact Gasoline Air Heater 7,500 BTU

### SCOPE OF DELIVERY

DESCRIPTION	PART NUMBER	Heater	Harness	Fuel System	Ducting	Mounting Bracket	Control Options / Timers	Fuel Pickup Pipe	Hardware Kit	Exhaust Pipe	Intake Pipe	Manuals
<b>B1LC COMPACT</b>												
Basic Heater 12 volt with fuel pump	20 1766 05 00 00	•										•
Universal Installation Kit 12 volt	20 2819 76 01 80		•	•	•				•	•	•	•
B1LC Compact with Thermostat	20 2817 66 01 00	•	•	•	•	•	•	•	•	•	•	•



**Hardware Kit INCLUDES:**

- Fuel Clamps
- Nuts
- Cable Ties
- Grommets
- Exhaust Clamps
- Mounting Screws

- Ducting Clamps
- Washers
- Routing Clamps
- End Caps
- Exhaust Brackets

**Fuel System INCLUDES:**

- Clamps
- 5mm Fuel Line
- Plastic Fuel Line
- 3.5mm Fuel Line

Refer to the Accessories Section for ducting components and additional accessories.  
For the addition of engine preheat, refer to the Combo Truck Kits Section.

**AIRTRONIC B5** GASOLINE AIR HEATER - 18,800 BTU

**AIRTRONIC D5** DIESEL AIR HEATER - 18,800 BTU

**SCOPE OF DELIVERY**

DESCRIPTION	PART NUMBER	Heater	Harness	Fuel System	Ducting	Mounting Bracket	Control Options / Timers	Fuel Pickup Pipe	Hardware Kit	Exhaust Pipe	Intake Pipe	Manuals
<b>AIRTRONIC B5 - GASOLINE</b>												
Basic Heater 12V with fuel pump with outlet hood	20 1859 05 00 00	•										•
<b>AIRTRONIC D5 - Carb Approved - DIESEL</b>												
Basic Heater 12V with fuel pump with outlet hood	25 2361 05 00 00	•										•
Basic Heater 24V with fuel pump with outlet hood	25 2362 05 00 00	•										•
<b>UNIVERSAL INSTALL KITS</b>												
JE Universal Installation Kit 12V and 24V	25 2361 80 00 00		•	•	•				•	•	•	
Espar Universal Installation Kit 12V and 24V <span style="background-color: yellow; border: 1px solid black; padding: 2px;">RECOMMENDED</span>	20 2823 61 05 80		•	•	•			•	•	•	•	
<b>AIRTRONIC D5 TRUCK KITS - Carb Approved - DIESEL</b>												
Truck Kit 12V (no control)	20 2823 61 05 10	•	•	•		•		•	•	•	•	•
Truck Kit 12V w/Thermostat	20 2823 61 05 11	•	•	•			•	•	•	•	•	•
<b>CARGO KITS</b>												
Cargo Kit 12V w/Thermostat Does Not Include Heater	20 2900 00 05 50		•	•		☐	•	•	•	■	•	•

☐ = cargo bracket  
 ■ = exhaust with plate



**Hardware Kit INCLUDES:**

- Fuel Clamps
- Nuts
- Cable Ties
- Grommets
- Exhaust Clamps
- Mounting Screws
- Ducting Clamps
- Washers
- Routing Clamps
- End Caps
- Exhaust Brackets

**Fuel System INCLUDES:**

- Clamps
- 5mm Fuel Line
- Plastic Fuel Line
- 3.5mm Fuel Line

Refer to the Accessories Section for ducting components and additional accessories.  
 For the addition of engine preheat, refer to the Combo Truck Kits Section.

1  
2  
3

**D8LC DIESEL AIR HEATER - 27,300 BTU****NOTE: No installation kits available for this heater.**

DESCRIPTION	PART NUMBER
<b>D8LC</b>	
Basic Heater 12 volt	25 1890 00 00 00
<b>INCLUDES:</b> Control Unit Fuel Pump Rheostat Switch External Temperature Sensor Combustion Air Tube Shock Mounts Mounting Bracket (large) Mounting Bracket (small)	
Basic Heater 24 volt	25 1891 00 00 00
<b>INCLUDES:</b> Control Unit Fuel Pump Rheostat Switch External Temperature Sensor Combustion Air Tube Shock Mounts Mounting Bracket (large) Mounting Bracket (small)	
<b>Accessories</b>	
<b>Harness</b>	
External Harness 20 feet	20 2900 70 08 02
External Harness 35 feet	20 2900 70 08 03
<b>Fuel</b>	
Fuel line 5.0mm black rubber, suction side	360 75 350
Fuel line 2.0mm white plastic, pressure side	890 31 117
Fuel line connector piece 3.5mm for 2mm fuel line	360 75 300
Fuel pick-up pipe 4mm	20 2900 20 20 58
Clamp 9mm for 3.5mm hose	10 2068 00 90 98
Clamp 11mm for 5mm hose	10 2068 01 10 98
<b>Exhaust</b>	
Flexible stainless steel exhaust 42mm	5530013
Exhaust clamp	152 09 004
Exhaust end cap for 42mm	22 1000 40 02 00
Flexible air intake 30mm SPECIAL ORDER	10 2114 25 00 00
<b>Controls</b>	
Thermostat 12 volt	5670097
Thermostat 24 volt	5670096
External Temperature Sensor, extension harness	25 1482 89 40 00

Refer to the Accessories Section for ducting components and additional accessories.

1

2

3

**NOTES:**

1

2

3

**HYDRONIC B5 SC** GASOLINE COOLANT HEATER - 17,100 BTU  
**HYDRONIC D5 SC** DIESEL COOLANT HEATER - 17,100 BTU

**SCOPE OF DELIVERY**

If installation is more than 6 feet from the fuel tank, kits with external fuel pumps are required.

DESCRIPTION	PART NUMBER	Heater	Harness	Fuel System *	Coolant Hose	Mounting Bracket	Control Options / Timers	Fuel Pickup Pipe	Hardware Kit <sup>o</sup>	Exhaust Pipe	Intake Pipe	Boxed	Manuals
<b>HYDRONIC D5 SC - DIESEL</b>													
Basic Heater 12 volt	25 2219 05 00 00	•											•
Universal Installation Kit 12 volt	25 2800 90 05 10		•	•	•	•			•	•	•		
Universal Installation Kit 12 volt w/Relay	25 2800 90 05 12		•	•	•	•			•	•	•		
Basic Heater 12 volt with External Fuel Pump	25 2325 05 00 00	•											•
Universal Installation Kit 12 volt	25 2800 90 05 11		•	•	•	•			•	•	•		
Basic Heater 24 volt	25 2147 05 00 00	•											•
Universal Installation Kit 24 volt	25 2009 80 00 00		•	•	•	•			•	•	•		
<b>HYDRONIC D5SC (INTERNAL FMP) TRUCK KITS - DIESEL</b>													
12 volt Kit	25 2822 19 05 20	•	•	•		•		•	•	•	•		•
12 volt Kit with 7 day timer <i>RECOMMENDED</i>	25 2822 19 05 21	•	•	•		•	•	•	•	•	•		•
12 volt Boxed Kit	25 2822 19 05 40	•	•	•		•		•	•	•	•	•	•
12 volt Boxed Kit with 7 day timer <i>RECOMMENDED</i>	25 2822 19 05 41	•	•	•		•	•	•	•	•	•	•	•
12 volt Boxed Kit with 7 day timer & vent tube pick-up pipe	25 2822 19 05 51	•	•	•		•	•	•	•	•	•	•	•
12 volt Boxed Kit with no pick-up pipe	25 2822 19 05 56	•	•	•		•		•	•	•	•	•	•
<b>HYDRONIC D5SC (EXTERNAL FMP) TRUCK KITS - DIESEL</b>													
12 volt Kit	25 2823 25 05 20	•	•	•		•		•	•	•	•		•
12 volt Kit with 7 day timer <i>RECOMMENDED</i>	25 2823 25 05 21	•	•	•		•	•	•	•	•	•		•
12 volt High altitude with mini timer	25 2823 25 05 23	•	•	•		•	•	•	•	•	•		•
12 volt Boxed Kit	25 2823 25 05 40	•	•	•		•		•	•	•	•	•	•
12 volt Boxed Kit with 7 day timer <i>RECOMMENDED</i>	25 2823 25 05 41	•	•	•		•	•	•	•	•	•	•	•
<b>HYDRONIC D5 SC OFF-HIGHWAY KITS - DIESEL</b>													
24 volt with External Fuel Pump	25 2821 47 05 20	•	•	•		•		•	•	•	•		•
24 volt with External Fuel Pump and timer	25 2821 47 05 21	•	•	•		•	•	•	•	•	•		•
Boxed 24 volt with External Fuel Pump	25 2821 47 05 55	•	•	•		•		•	•	•	•	•	•
Boxed 24 volt with External Fuel Pump and timer	25 2821 47 05 57	•	•	•		•	•	•	•	•	•	•	•
<b>HYDRONIC D5 SC AUTOMOTIVE PICK-UP KITS - DIESEL</b>													
12 volt with 7 day timer	25 2822 19 05 22	•	*	•	•	•	•	•	•	•	•		•
<b>HYDRONIC B5 SC - GASOLINE</b>													
Basic Heater 12 volt with external fuel pump	20 1820 05 00 00	•											•
Universal Installation Kit 12 volt	25 2800 90 05 11		•	•	•	•			•	•	•		
<b>HYDRONIC B5SC TRUCK KIT - GASOLINE</b>													
12 volt with External Fuel Pump	20 2818 20 05 20	•	•	•		•		•	•	•	•		•
<b>HYDRONIC B5 SC AUTOMOTIVE PICK-UP KIT - GASOLINE</b>													
12 volt with External Fuel Pump	20 2818 20 05 22	•	*	•	•	•	•	•	•	•	•		•
<b>HYDRONIC 4/5 SC COOLANT PUMP SERVICE KIT</b>													
	25 2800 60 00 05												

• = includes blower relay connection  
 \* = harness has blower relay

Refer to the Accessories Section for ducting components and additional accessories.  
 For the addition of cab heat, refer to the Combo Truck Kits Section.

1  
2  
3

**HYDRONIC 5 SC** DIESEL COOLANT HEATER - 17,100 BTU

**Spare parts**

25 2219 05 00 00

**HYDRONIC 5 SC** DIESEL COOLANT HEATER - 17,100 BTU W/EXTERNAL FUEL PUMP

25 2325 05 00 00

The parts shown are for the most common 12V model heater of this type - model #-, top right corner

DESCRIPTION	PART NUMBER
Combustion Air Blower	20 1759 99 1500
Electronic Control Unit (HYDRONIC 4)	22 5201 03 0001
Electronic Control Unit (HYDRONIC 5)	22 5201 01 9002
Coolant Pump	25 2219 25 0000
Glow Pin with Cable	25 2106 01 1000
Fuel Metering Pump internal	22 4504 03 0000
Fuel Metering Pump external	22 4517 04 0000
Flame Sensor	25 1920 35 0000
Overheat Sensor with Cable	25 2219 01 2000
Fuse 25A Blade Type	204 00 089
Flexible Exhaust Tube, 24mm	360 61 550
Timer, 7-Day	22 1000 30 3600
Programmable Timer, 12 Volt	5670433
Fuel Pump Screen	20 1312 00 00 06



Spare parts shown are common for Hydronic 4 + 5 heaters.  
 Hydronic 5 Heaters used in ParkSmart + Max Power Systems may have a different control unit.  
 Please refer to serial # on heater.

1  
2  
3

# PICK-UP TRUCK KITS

## HYDRONIC D5 DIESEL COOLANT HEATER - 17,100 BTU

### SCOPE OF DELIVERY

If installation is more than 6 feet from the fuel tank, kits with external fuel pumps are required.

DESCRIPTION	PART NUMBER	Heater	Harness	Fuel System	Coolant Hose	Mounting Bracket	Control Options / Timers	Fuel Pickup Pipe	Hardware Kit	Exhaust Pipe	Intake Pipe	Boxed	Manuals
<b>PICK-UP TRUCK KITS (AFTER MARKET)</b>													
<b>DODGE KITS</b>													
2003 - 2007 5.9 L with mini timer	25 2822 19 05 32	•	*	•		•	•	•	•	•	•		•
2007 - 2008 6.7 L with mini timer	25 2800 10 05 35	•	*	•		•	•	•	•	•	•		•
<b>GM DURAMAX KITS</b>													
Frame dimensions not larger than 225mm high, 77mm wide													
Mini Timer and external FMP Right side mount	25 2823 25 05 75	•	•	•		•	•	•	•	•	•		•
<b>FORD POWERSTROKE KITS</b>													
Frame rail dimensions not larger than 204mm high, 77mm wide													
Mini timer and external FMP	25 2823 25 05 85	•	•	•		•		•	•	•	•		•
<b>UNIVERSAL PICK UP TRUCK INSTALLATION KIT</b>													
D5E Diesel Pick Up Truck kit	25 2825 26 05 22	•	•	•		•		•	•	•	•		•
B5E Gasoline Pick Up Truck kit	25 2819 04 05 00	•	•	•	•	•		•	•	•	•		•
<b>SPRINTER CONVERSION KIT WITH MINI-TIMER</b>													
Converts auxiliary heater into preheater (2006 and earlier models)	24 0212 00 00 00												
<b>RELATED PARTS</b>													
Blower Control Module 12/24V	25 2800 70 40 40												
Mini Timer (Green Display)	22 1000 31 60 00												
EasyStart T Controller	22 1000 32 88 00												

\* = harness has blower relay



**Hardware Kit INCLUDES:**

- Fuel Clamps
- Nuts
- Cable Ties
- Grommets
- Exhaust Clamps
- Mounting Screws

- Ducting Clamps
- Washers
- Routing Clamps

- End Caps
- Exhaust Brackets

**Fuel System INCLUDES:**

- Clamps
- 5mm Fuel Line
- Plastic Fuel Line
- 3.5mm Fuel Line

For spare parts refer to Hydronic D5 listing on page 13  
 Refer to the Accessories Section for ducting components and additional accessories.

1  
2  
3

**HYDRONIC II B5 E** GASOLINE COOLANT HEATER - 17,100 BTU  
**HYDRONIC II D5 E** DIESEL COOLANT HEATER - 17,100 BTU

**SCOPE OF DELIVERY**

DESCRIPTION	PART NUMBER
<b>HYDRONIC II D5 E - DIESEL</b>	
Basic Heater 12 volt	25 2526 05 00 00
JE Universal installation kit 12 volt	25 2526 80 00 00
<b>HYDRONIC II D5E TRUCK KIT - DIESEL</b>	
12 volt with External Water and Fuel Pump	25 2825 26 05 20
12 volt Automotive installation kit	25 2825 26 05 22
Boxed 12 volt with External Water and Fuel Pump	25 2825 26 05 40
<b>HYDRONIC II B5E - GASOLINE</b>	
12 volt with External Water and Fuel Pump	20 1904 05 00 00
12 volt Automotive Installation Kit	25 2819 04 05 00
JE Universal installation kit 12 volt	25 2526 80 00 00

Heater	Harness	Fuel System	Coolant Hose	Mounting Bracket	Control Options / Timers	Fuel Pickup Pipe	Hardware Kit	Exhaust Pipe	Intake Pipe	Boxed	Manuals
•											•
	↔	•	•	•		•	•	•	•		
•	•	•		•		•	•	•	•		•
•	•	•	•	•		•	•	•	•		•
•	•	•		•		•	•	•	•	•	•
•	•	•	•	•		•	•	•	•		•
•	•	•	•	•		•	•	•	•		•

↔ = Includes blower relay connection

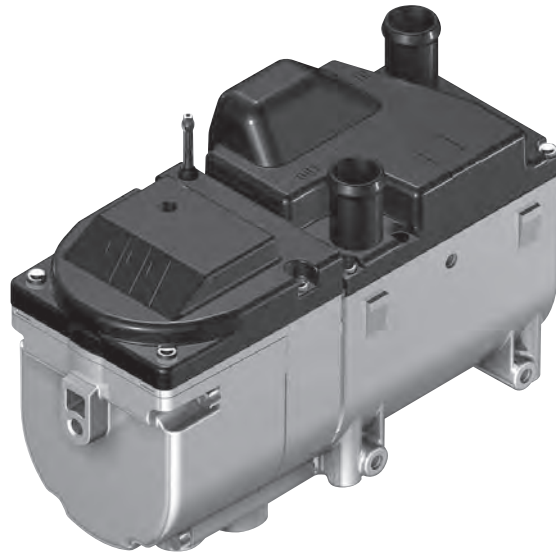

**HYDRONIC B5 S** GASOLINE COOLANT HEATER - 17,100 BTU  
**HYDRONIC D5 S** DIESEL COOLANT HEATER - 17,100 BTU

**SCOPE OF DELIVERY**

If installation is more than 6 feet from the fuel tank, kits with external fuel pumps are required.

DESCRIPTION	PART NUMBER	Heater	Harness	Fuel System	Coolant Hose	Mounting Bracket	Control Options / Timers	Fuel Pickup Pipe	Hardware Kit	Exhaust Pipe	Intake Pipe	Boxed	Manuals
<b>HYDRONIC D5 S - DIESEL</b>													
Basic Heater 12 volt	25 2217 05 00 00	•											•
Basic Heater 12 volt w/Universal install kit	25 2386 05 00 00	•	→	•	•	•			•	•	•		•
Basic Heater 24 volt	25 2218 05 00 00	•											•
Universal Installation Kit 24 volt (Limited Stock)	25 2218 80 00 00			•	•	•			•	•	•		
Basic Heater 24 volt	25 2146 05 00 00	•											•
Universal Installation Kit 24 volt	25 2009 80 00 00		→	•	•	•			•	•	•		
<b>HYDRONIC D5S TRUCK KIT - DIESEL</b>													
12 volt with External Water and Fuel Pump	25 2822 17 05 20	•	•	•		•		•	•	•	•		•
12 volt with External Water and Fuel Pump with timer	25 2822 17 05 21	•	•	•		•	•	•	•	•	•		•
Boxed 12 volt with water pump and fuel pump mounted inside box	25 2822 17 05 45	•	•	•		•		•	•	•	•	•	•
Boxed 12 volt with water pump mounted outside box	25 2822 17 05 40	•	•	•		•		•	•	•	•	•	•
<b>HYDRONIC D5S OFF-HIGHWAY KIT - DIESEL</b>													
24 volt with External Water and Fuel Pump	25 2822 18 05 20	•	•	•		•		•	•	•	•		•
<b>HYDRONIC B5 S - GASOLINE</b>													
Basic Heater 12 volt with external water and fuel pump	20 1819 05 00 00	•											•
<b>HYDRONIC B5 S - GASOLINE</b>													
12 volt with external water and fuel pump with universal installation kit	20 1862 05 00 00	•	→	•	•	•		•	•	•	•		•

→ = includes blower relay connection

1  
2  
3

## AIRTRONIC 2 / HYDRONIC 5 Combo Kits DIESEL 12 volt only

### SCOPE OF DELIVERY

SCOPE OF DELIVERY			Heater	Harness	Fuel System	Coolant Hose	Mounting Bracket	Control Options / Timers	Fuel Pickup Pipe	Hardware Kit	Exhaust Pipe	Intake Pipe	Boxed	Manuals
DESCRIPTION	PART NUMBER													
<b>AIRTRONIC 2 / HYDRONIC 5 SC - DIESEL</b>														
Truck Kit	INCLUDES:	7-Day Timer Thermostat 12 volt	20 2812 15 20 50	•	•	•	•	•	d	•	•	•		•
Truck Kit	INCLUDES:	7-Day Timer Mini Controller	20 2812 15 20 56	•	•	•	•	•	d	•	•	•		•
Truck Kit with External Fuel Pump	INCLUDES:	7-Day Timer Mini Controller	20 2812 15 20 58	•	•	•	•	•	d	•	•	•		•
Boxed Truck Kit	INCLUDES:	7-Day Timer Mini Controller	20 2812 15 20 57	•	•	•	•	•	d	•	•	•	•	•
<b>AIRTRONIC 2 / HYDRONIC 5 S - DIESEL</b>														
Truck Kit	INCLUDES:	7-Day Timer Mini Controller	20 2812 15 20 63	•	•	•	•	•	d	•	•	•		•
Boxed Truck Kit	INCLUDES:	7-Day Timer Digi-Max Controller	20 2812 15 20 60	•	•	•	•	•	d	•	•	•	•	•
<b>AIRTRONIC 2 / HYDRONIC 5 E - DIESEL</b>														
Truck Kit		No Timer Digi-Max Controller	20 2812 15 20 61	•	•	•	•	•	d	•	•	•		•
Boxed Truck Kit		No Timer Digi-Max Controller	20 2812 15 20 62	•	•	•	•	•	d	•	•	•	•	•

d = double fuel Pick-up pipe

## AIRTRONIC 4 / HYDRONIC 5 Combo Kits DIESEL 12 Volt only

### SCOPE OF DELIVERY

DESCRIPTION	PART NUMBER	Heater	Harness	Fuel System	Coolant Hose	Mounting Bracket	Control Options / Timers	Fuel Pickup Pipe	Hardware Kit	Exhaust Pipe	Intake Pipe	Boxed	Manuals
<b>AIRTRONIC 4 / HYDRONIC 5 - Carb Approved</b>													
Truck Kit	INCLUDES: 7-Day Timer Mini Controller	20 2812 15 40 50	•	•	•	•	•	d	•	•	•		•
Boxed Truck Kit	INCLUDES: 7-Day Timer Mini Controller	20 2812 15 40 51	•	•	•	•	•	d	•	•	•	•	•

**NOTES:**

1

2

3

## HYDRONIC 10 / M DIESEL COOLANT HEATER - 32,400 BTU

### SCOPE OF DELIVERY

DESCRIPTION	PART NUMBER	Heater	Harness	Fuel System	Coolant Hose	Mounting Bracket	Control Options / Timers	Fuel Pickup Pipe	Hardware Kit	Exhaust Pipe	Intake Pipe	Boxed	Manuals
<b>HYDRONIC 10 / M</b>													
Basic Heater 12 volt with Fuel Pump	25 2160 05 00 00	•											•
Universal Installation Kit 12 volt	25 2821 60 10 80		•	•		•			•	•	•		
Basic Heater 24 volt with Blinkcode	25 2227 05 00 00	•											•
Universal Installation Kit 12 and 24 volt	25 2822 27 10 80		•	•		•			•	•	•		
<b>HYDRONIC 10 / M - BOXED KITS</b>													
Boxed 12 volt with Internal Fuel Pump (max. 6ft. of fuel line)	25 2821 60 10 55	•	•	•		•		•	•	•		•	•
Boxed 12 volt with External Fuel Pump	25 2821 60 10 56	•	•	•		•		•	•	•		•	•
Boxed 24 volt	25 2822 27 10 55	•	•	•		•		•	•	•		•	•
Boxed 24 volt with External Fuel Pump	25 2822 27 10 56	•	•	•		•		•	•	•		•	•

## HYDRONIC M DIESEL COOLANT HEATER - 32,400 BTU - 24V

## Spare parts

25 2227 05 00 00

DESCRIPTION	PART NUMBER
Combustion Air Blower	25 2161 99 1500
Flame Sensor	25 1816 01 0300
Overheat Sensor	25 1997 99 4100
Temperature Sensor	25 1816 99 0114
Sensor O-Ring	320 75 111
Control Unit	22 5302 00 1004
Fuse 20A Blade Type	5670055
Coolant Pump	25 1816 25 01 00
Coolant Pump O-Ring	320 75 110
Fuel Metering Pump	25 1963 45 00 00
Flexible Exhaust Tube, 30mm	360 61 580
Fuel Hose, 3.5mm	360 75 300
Fuel Hose, 5.0mm	360 75 350
Fuel Line, 2.0mm Clear Plastic	890 31 117
Fuel Line, 3.5mm Black Plastic	890 31 101
Clamp 9mm	10 2063 00 90 98
Clamp 11mm	10 2063 01 10 98
Cable Tie, 197mm	5590003
Timer, 7-Day	22 1000 30 36 00
Programmable Timer, 12 Volt	5670433
Fuel Pump Screen	20 1312 00 00 06

**Hardware Kit INCLUDES:**

- Fuel Clamps
- Nuts
- Cable Ties
- Grommets
- Exhaust Clamps
- Mounting Screws
- Ducting Clamps
- Washers
- Routing Clamps
- End Caps
- Exhaust Brackets

**Fuel System INCLUDES:**

- Clamps
- 5mm Fuel Line
- Plastic Fuel Line
- 3.5mm Fuel Line

Refer to the Accessories Section for ducting components and additional accessories.  
For the addition of engine preheat, refer to the Combo Truck Kits Section.

1  
2  
3

## HYDRONIC M-II SERIES: 27,300, 32,450, 42,000 BTU - CARB APPROVED

### SCOPE OF DELIVERY

DESCRIPTION	PART NUMBER	Heater	Harness	Fuel System	Coolant Hose	Mounting Bracket	Control Options / Timers	Fuel Pickup Pipe	Hardware Kit	Exhaust Pipe	Intake Pipe	Boxed	Manuals
HYDRONIC M8 biodiesel 12 volt	25 2470 05 00 00	•						•					•
HYDRONIC M8 biodiesel 24 volt	25 2471 05 00 00	•						•					•
HYDRONIC M10 12 volt	25 2434 05 00 00	•											•
HYDRONIC M10 24 volt	25 2435 05 00 00	•											•
HYDRONIC M12 12 volt	25 2472 05 00 00	•											•
HYDRONIC M12 24 volt	25 2473 05 00 00	•											•
HYDRONIC M8 biodiesel 12 volt Boxed Kit	25 2824 70 08 10	•	•	•	•	•	•	•	•	•	•	•	•
HYDRONIC M8 biodiesel 24 volt Boxed Kit	25 2824 71 08 10	•	•	•	•	•	•	•	•	•	•	•	•
HYDRONIC M10 12 volt Boxed Kit	25 2824 34 10 10	•	•	•	•	•	•	•	•	•	•	•	•
HYDRONIC M10 24 volt Boxed Kit	25 2824 35 10 10	•	•	•	•	•	•	•	•	•	•	•	•
HYDRONIC M12 12 volt Boxed Kit	25 2824 72 12 10	•	•	•	•	•	•	•	•	•	•	•	•
HYDRONIC M12 24 volt Boxed Kit	25 2824 73 12 10	•	•	•	•	•	•	•	•	•	•	•	•
HYDRONIC M12 12 volt Boxed Kit w/high Capacity Pump	25 2824 72 00 12	•	•	•	•	•	•	•	•	•	•	•	•
HYDRONIC M12 24 volt Boxed Kit w/high Capacity Pump	25 2824 73 00 24	•	•	•	•	•	•	•	•	•	•	•	•
<b>UNIVERSAL INSTALLATION KITS</b>													
JE Universal Installation Kit 12V / 24V	25 2435 80 00 00		*	•	•	•	•	•	•	•	•	•	•
Espar Universal Install 12V with diagnostic connection	25 2800 90 10 12		•	•	•	•	•	•	•	•	•	•	•
Espar Universal Install 24V with diagnostic connection	25 2800 90 10 24		•	•	•	•	•	•	•	•	•	•	•

\* = Harness has blower motor relay

<b>HYDRONIC M8 12V</b> DIESEL COOLANT HEATER - 27,300 BTU	<b>25 2470 05 00 00</b>
<b>HYDRONIC M8 24V</b> DIESEL COOLANT HEATER - 27,300 BTU	<b>25 2471 05 00 00</b>
<b>HYDRONIC M10 12V</b> DIESEL COOLANT HEATER - 32,450 BTU	<b>25 2434 05 00 00</b>
<b>HYDRONIC M10 24V</b> DIESEL COOLANT HEATER - 32,450 BTU	<b>25 2435 05 00 00</b>
<b>HYDRONIC M12 12V</b> DIESEL COOLANT HEATER - 42,000 BTU	<b>25 2472 05 00 00</b>
<b>HYDRONIC M12 24V</b> DIESEL COOLANT HEATER - 42,000 BTU	<b>25 2473 05 00 00</b>

### Spare parts

DESCRIPTION	PART NUMBER
Burner	25 2435 99 1100
Casing for Heat Exchanger	25 2435 99 0102
Water Pump 12 Volt	25 2434 99 2501
Water Pump 24 Volt	25 2435 99 2501
Flame Sensor	25 1920 35 0000
Glow Plug 12 Volt	25 2434 01 0100
Glow Plug 24 Volt	25 2435 01 0100
Cable Harness	25 2435 25 0200
Temperature Sensor	25 2435 40 0100
Plastic Cover	25 2435 99 0103
Seal for Combustion Chamber	25 2435 01 0010
O-Ring (19.8 x 2.3)	22 1000 70 0017
O-Ring (117.07 x 3.53)	22 1000 70 0015
Sensor Spring	25 2281 01 0009
Atomizing Screen	25 2069 10 0102
Hose Clip	152 61 004
Timer, 7-Day	22 1000 30 3600
Programmable Timer 12 Volt	5670433
Fuel Pump Screen	20 1312 00 00 06
Fuel Meter Pump 12 volt	22 4617 01 00 00
Fuel Meter Pump 24 volt	22 4618 01 00 00



1  
2  
3

# E-Guardian DIESEL / WATER

## SCOPE OF DELIVERY

DESCRIPTION	BTU	PART NUMBER	Heater	Harness	Fuel System	Coolant Hose	Mounting Bracket	Control Options / Timers	Fuel Pickup Pipe	Hardware Kit	Exhaust Pipe	Intake Pipe	Boxed	Manuals
<b>E-Guardian HYDRONIC D5 KITS - Carb Approved</b>														
Basic D5 E-Guardian 12V Kit	17,100 BTU	25 2823 25 0506	•	•	•		•		•	•	•			•
Boxed D5 E-Guardian 12V Kit	17,100 BTU	25 2823 25 0500	•	•	•		•	•	•	•	•	•	•	•
Boxed D5 E-Guardian 12V High Altitude Kit	17,100 BTU	25 2823 25 0501	•	•	•		•	•	•	•	•	•	•	•
Boxed D5 E-Guardian 12V New York Kit	17,100 BTU	25 2823 25 0505	•	•	•		•	•	•	•	•	•	•	•
Boxed D5E H-II E-Guardian 12V Kit	17,100 BTU	25 2825 26 0500	•	•	•		•	•	•	•	•	•	•	•
<b>E-Guardian HYDRONIC M-II KITS - Carb Approved</b>														
Boxed M-II 10 KW Heater 12 V Kit	32,450 BTU	25 2824 34 10 00	•	•	•		•	•	•	•	•	•	•	•
Boxed M-II 12 KW Heater 12 V Kit	42,000 BTU	25 2824 72 12 00	•	•	•		•	•	•	•	•	•	•	•
Basic M-II 12 KW Heater 12 V Kit	42,000 BTU	25 2824 72 12 01	•	•	•		•		•	•	•			•
Boxed M-II 12 KW Heater 12 V New York Kit	42,000 BTU	25 2824 72 12 05	•	•	•		•	•	•	•	•	•	•	•
<b>Spare Parts:</b>														
E-Guardian Coolant Pump		25 2596 25 01 00												
E-Guardian 12 Replacement Heater		25 2596 05 00 00												



**Hardware Kit INCLUDES:**

- Fuel Clamps
- Nuts
- Cable Ties
- Grommets
- Exhaust Clamps
- Mounting Screws
- Ducting Clamps
- Washers
- Routing Clamps
- End Caps
- Exhaust Brackets

**Fuel System INCLUDES:**

- Clamps
- 5mm Fuel Line
- 1.5mm Fuel Line
- 3.5mm Fuel Line

For spare parts refer to the Hydronic D5 listing on page 13, and the *Hydronic M-II* refer to page 21  
Refer to the Accessories Section for ducting components and additional accessories.

1  
2  
3

## HYDRONIC L-II SERIES: 55,000, 82,000, 102,000, 120,000 BTU

### SCOPE OF DELIVERY

DESCRIPTION	PART NUMBER
<b>HYDRONIC L 16</b>	
Basic Heater 24V	25 2486 02 0000
<b>HYDRONIC L 24</b>	
Basic Heater 24 volt	25 2487 02 00 00
<b>HYDRONIC L 24 Compact</b>	
Water pump Flowtronic 5000 and fuel filter pre-assembled	25 2487 05 00 00
<b>HYDRONIC L 30</b>	
Basic Heater 24 volt	25 2488 02 00 00
<b>HYDRONIC L 30 Compact</b>	
Water pump Flowtronic 5000 and fuel filter pre-assembled	25 2599 05 00 00
<b>HYDRONIC L 35</b>	
Basic Heater 24 volt	25 2600 02 00 00
<b>HYDRONIC L 35 Compact</b>	
Water pump Flowtronic 5000 and fuel filter pre-assembled	25 2489 05 00 00

### ACCESORIES

<b>HARNESS</b>	Universal Harness	20 2900 70 05 10
	Compact Heater Harness	20 2900 70 05 11
<b>FUEL</b>	Filter kit for basic kit	25 2800 20 00 05
	Nipple and Nut Connectors for compact version (1 required)	20 2900 20 20 71
	Fuel Line 5.0mm black rubber	360 75 350
	Clamps 11mm	10 2068 01 10 98
	Fuel Pick-up with Return	20 2900 20 20 59
<b>EXHAUST</b>	Flexible Stainless Steel Exhaust Tube 70mm	5530015
	Muffler Clamp 3"	5530004
	Exhaust Elbow (70mm exhaust) D30 / D35	22 1000 40 03 00
<b>PUMPS</b>	Coolant Pump 24volt (5,000 L/hr)	25 1818 29 00 00
	Flowtronic Coolant Pump 24 volt (6,000 L/hr)	25 1818 27 00 00
<b>CONTROLS</b>	Push / Pull Switch 24 volt (supplied with harness)	5670008
	7-Day Timer Kit 24 volt	22 1000 30 36 00
	7-Day Timer Kit 24 volt with Bezel and Mounting Bracket	20 2900 70 02 30
	Bezel and Mounting Bracket for 7-day timer	25 1482 70 01 00
<b>12V TO 24V POWER CONVERTER KITS</b>		
	<i>Hydronic 16 with/without coolant pump</i>	25 2800 90 12 23
	<i>Hydronic 24, 30, 35 without pump</i>	25 2800 90 12 23
	<i>Hydronic 16, 24, 30, 35 with/without coolant pump</i>	25 2800 90 12 24



When using Artic Fox Systems, be sure and specify heaters with high capacity pumps.

## HYDRONIC M-II OFF HIGHWAY KITS HYDRONIC L-II OFF HIGHWAY KITS

### SCOPE OF DELIVERY

DESCRIPTION	PART NUMBER	Heater	Harness	Fuel System	Coolant Hose	Mounting Bracket	Control Options / Timers	Fuel Pickup Pipe	Hardware Kit	Exhaust Pipe	Intake Pipe	Boxed	Manuals
<b>M-II OFF HIGHWAY</b>													
<i>HYDRONIC 12</i> M-II Boxed Off-Highway Assembly 12V	25 2824 72 12 20	•	•	•		•	•	•	•	•	•	•	•
<b>L-II OFF HIGHWAY</b>													
<i>HYDRONIC 16</i> L-II Boxed Off-Highway Assembly 12V	25 2800 10 1612	•	•			*		•	•			•	•
<i>HYDRONIC 16</i> L-II Boxed Off-Highway Assembly 24V	25 2800 10 1600	•	•			*		•	•			•	•
<i>HYDRONIC 24</i> L-II Boxed Off-Highway Assembly 12V	25 2800 10 2412	•	•			*		•	•			•	•
<i>HYDRONIC 24</i> L-II Boxed Off-Highway Assembly 24V	25 2800 10 2400	•	•			*		•	•			•	•
<i>HYDRONIC 30</i> L-II Boxed Off-Highway Assembly 12V	25 2800 10 3012	•	•			*		•	•			•	•
<i>HYDRONIC 30</i> L-II Boxed Off-Highway Assembly 12V w/6000 L pump	25 2800 10 3612	•	•			*		•	•			•	•
<i>HYDRONIC 30</i> L-II Boxed Off-Highway Assembly 24V	25 2800 10 3000	•	•			*		•	•			•	•
<i>HYDRONIC 30</i> L-II Boxed Off-Highway Assembly 24V w/6000 L pump	25 2800 10 3600	•	•			*		•	•			•	•
<i>HYDRONIC 35</i> L-II Boxed Off-Highway Assembly 12V	25 2800 10 3512	•	•			*		•	•			•	•
<i>HYDRONIC 35</i> L-II Boxed Off-Highway Assembly 12V w/6000 L pump	25 2800 10 5612	•	•			*		•	•			•	•
<i>HYDRONIC 35</i> L-II Boxed Off-Highway Assembly 24V	25 2800 10 3500	•	•			*		•	•			•	•
<i>HYDRONIC 35</i> L-II Boxed Off-Highway Assembly 24V w/6000 L pump	25 2800 10 5624	•	•			*		•	•			•	•

\* = Mounting holes on base. No mounting hardware included

- Packaged for Off-Highway and oilfield applications
- 12 and 24 volt options
- Eliminate cold starts
- Minimize diesel exhaust emissions
- Rugged, compact
- Versatile fluid pre-heating
- Standard with pre-heated nozzle



1  
2  
3

## ACCESSORIES PARTS GUIDE

CHAPTER	TITLE	CONTENT	PAGE
3	PARTS GUIDE		
		Timers and Controlers Table	28
		Control Options and Timers	29-31
		Testers, Adapters and Special Tools	32-33
		Fuel System	34-37
		Mounting	38-40
		Bulk Wiring	41
		Fuse Holders, Fuses and Breakers	42-43
		Terminals and Connectors	44-47
		Power Converter	48
		Exhaust	50-53
		Ducting	54-60
		Coolant Pumps	61
		Plumbing	62-65
		Fuel System Guide	66
		Ducting Rating Guide	67
		AIRTRONIC 2	68-69
		AIRTRONIC 4	70-71
		B1LC compact	72-73
		B3LC compact	74-75
		B/D5LC	76-77
		D8LC	78-79

## TIMERS AND CONTROLLERS

### FOR AIR HEATERS



### FOR COOLANT HEATERS

AVAILABLE FUNCTIONS	FOR AIR HEATERS		FOR COOLANT HEATERS		
	DIGI-MAX CONTROLLER	MINI-CONTROLLER	PROGRAMABLE TIMER	7 DAY TIMER	MULTI-FUNCTION SWITCH
Programmable Timer			•	•	
Multiple Starts - Day / Week			•		
Ambient Air Temp Sensor	•			Cabin temp sensor	AVAILABLE
Diagnostic Code Retrieval	•			•	
Standard Fan Mode	•	•			
10-Hour Automatic Shutoff	•			2 hour max. programmed run time	
Manual Start Mode	•	•	•	•	•
Program Memory			•	•	
Programmable LVD	•				•
Accepts External Inputs		•		•	AVAILABLE

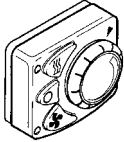
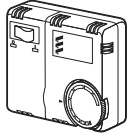
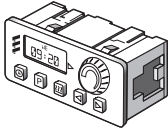
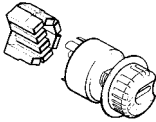
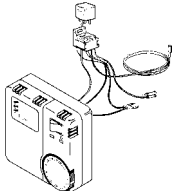
# AIR HEATERS CONTROL OPTIONS AND TIMERS

DESCRIPTION	PART NUMBER	AIRTRONIC D2	AIRTRONIC D4	B1LC compact	B3LC compact	AIRTRONIC D5	D8LC	HYDRONIC 4/5	HYDRONIC 10 / M	HYDRONIC 16/24/30/35	HYDRONIC M-II
<b>AIR HEATERS</b>											
Digi-Max Controller	20 2800 70 1500	•	•			•					
											
Mini Controller 12 and 24 volt	22 1000 32 07 00	•	•			•					
Mini Controller Knob	5699849	•	•			•					
											
Thermostat 12 volt	5670097	•	•	•	•	•					
Thermostat 24 volt	5670096	•	•	•	•	•					
Thermostat Harness (4.6M or 15 feet)	20 2900 70 01 09			•							
Thermostat Knob	2199981										
											
7-Day Timer with Diagnostics 12 and 24 volt	22 1000 30 40 00	•	•	•	•	•	•				
7-Day Timer Kit	20 2900 70 02 35	•	•	•	•	•	•				
											
Rheostat Switch 12 volt	25 1895 71 00 00	•	•	•	•	•	•				
Rheostat Switch 24 volt	25 1896 71 00 00	•	•	•	•						
Thermostat Switch Harness (4.6M or 15 feet)	20 2900 70 01 11	•	•	•	•						
											
Thermostat Bunk Relay Kit 12 volt	20 2900 70 00 97								•		
Thermostat only (On/Off)	29 2100 30 01 84	•	•	•	•	•	•	•	•	•	•
											

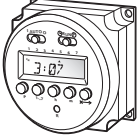
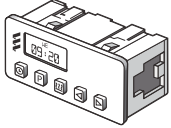
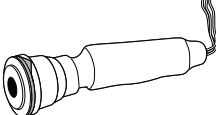
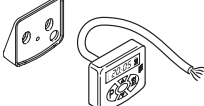
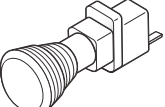
# HYDRONIC HEATERS CONTROL OPTIONS AND TIMERS

DESCRIPTION	PART NUMBER	AIRTRONIC D2	AIRTRONIC D4	B1LC compact	B3LC compact	AIRTRONIC D5	D8LC	HYDRONIC 4/5	HYDRONIC 10 / M	HYDRONIC 16/24/30/35	HYDRONIC M-II
<b>COOLANT HEATERS</b>											
Programmable Timer	12 V 24 V	5670433						•	•	•	•
		5670434						•	•	•	•
											
7-Day Timer with Diagnostics 12 and 24 volt		22 1000 30 36 00						•	•	•	T
7-Day Timer Kit		20 2900 70 02 30						•	•	•	T
 <span style="background-color: yellow; border: 1px solid black; padding: 2px;">RECOMMENDED</span>											
Programmable Timer with LVD		25 2800 70 10 10	•	•	•	•	•	•	•	•	•
Programmable Timer with LVD, Dual Input		25 2800 70 20 20	•	•	•	•	•	•	•	•	•
Programmable Timer with LVD, Dual Outputs-Detached		25 2800 70 30 30	•	•	•	•	•	•	•	•	•
Push button with 24" leads to be used with detached timer		25 2800 70 30 35	•	•	•	•	•	•	•	•	•
											
Mini Timer (Green Display) 12 and 24 volt		22 1000 31 60 00						•	•	•	•
Mini Timer (Blue Display) 12 and 24 volt		22 1000 32 18 00						•	•	•	•
											
Push / Pull Switch 12 volt		5670007	•	•	•	•	•	•	•	•	•
Push / Pull Switch 24 volt		5670008	•	•	•	•	•	•	•	•	•
Replacement Bulb 12 volt		207 00 005									
Replacement Bulb 24 volt		207 00 006									
											
Remote Starter Kit 12 volt (used with 7-Day Timer or EasyStart Timer)		20 2900 70 01 50	•	•	•	•	•	•	•	•	•
											

T = Can only be used as timer. Diagnostic not compatible

1  
2  
3

# HYDRONIC HEATERS CONTROL OPTIONS AND TIMERS

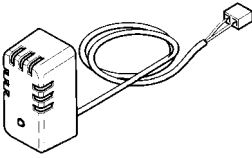
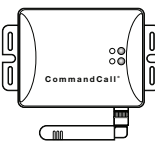
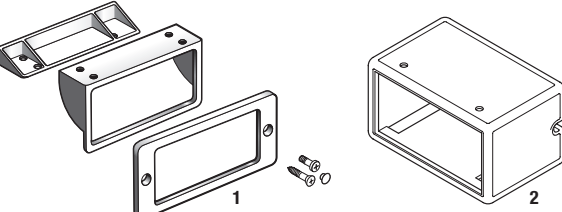
DESCRIPTION	PART NUMBER	AIRTRONIC D2	AIRTRONIC D4	B1LC compact	B3LC compact	AIRTRONIC D5	D8LC	HYDRONIC 4/5	HYDRONIC 10 / M	HYDRONIC 16/24/30/35	HYDRONIC M-II
EasyStart T Controller	22 1000 32 88 00	•	•	L	L	•	L	•	•	•	•
											
Remote Temperature Sensor	25 1774 89 03 00	•	•	•	•		•				
Extension Harness for D1LC (1830) and D3LC	25 1482 89 40 00					•					
											
CommandCall Remote Control (works over cell phone network. Needs SIM card.)	25 2800 70 00 10	•	•	•	•	•	•	•	•	•	•
											
7-DAY TIMER ACCESSORIES Complete Bracket Kit with Cosmetic Bezel and Bracket	25 1482 70 01 00	•	•	•	•	•	•	•	•	•	•
Housing for 7-Day Timer	25 1482 89 00 15	•	•	•	•	•	•	•	•	•	•
Replacement Bulbs 12 volt (5/bag)	22 1000 30 94 00										
Replacement Bulbs 24 volt (5/bag)	22 1000 30 89 00										
											

1

2

1

2

3



# TESTERS / ADAPTERS / SPECIAL TOOLS

**DESCRIPTION** **PART NUMBER**

Terminal Removal Tool 1.6mm 206 00 205  
 Terminal Removal Tool 2.8mm 206 00 215

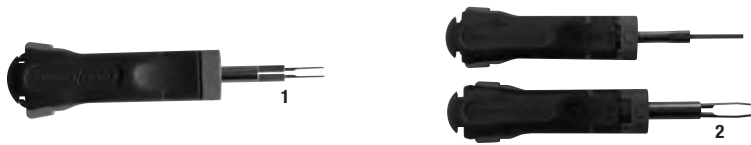

Wire Crimper 5670003



Fuel Line Cutter 5520003



Brass Glow Plug Brush 5590002



AIRTRONIC D2 Demo Kit 12 volt 20 2820 69 02 83



AIRTRONIC D2  
 AIRTRONIC D4  
 B1LC compact  
 B3LC compact  
 AIRTRONIC D5  
 D8LC  
 HYDRONIC 4/5  
 HYDRONIC 10 / M  
 HYDRONIC 16/24/30/35  
 HYDRONIC M-II

1  
2

1  
2  
3

# FUEL SYSTEM Refer to Fuel System Guide on page 66, to help plan your fuel system.

DESCRIPTION	PART NUMBER	AIRTRONIC D2	AIRTRONIC D4	B1LC compact	B3LC compact	AIRTRONIC D5	D8LC	HYDRONIC 4/5	HYDRONIC 10 / M / M-II	HYDRONIC 16/24/30/35	
Single Pick-up Pipe 2.0mm Universal (Drill or 1/2" NPT fitting)	20 2900 20 20 10	•	•	•	•	•		•			1
Single Pick-up Pipe 2.0mm (66 cm or 26") <small>RECOMMENDED</small>	20 2900 20 20 42	•	•	•	•	•		•			5
Double Pick-up Pipe 2.0mm (56 cm or 22")	20 2900 20 20 57	•	•	•	•	•		•			2
Double Pick-up Pipe 2.0mm (1/2" NPT)	20 2900 20 21 07	•	•	•	•	•		•			3
Single Pick-Up Pipe 4.0mm universal (Drill or 1/2" NPT fitting) <small>RECOMMENDED</small>	20 2900 20 20 50						•	•			
Fuel Pick-up pipe with Ring Fitting	20 2900 20 20 11	•	•	•	•	•		•			4
Single Pick-up Pipe 4.0mm (61 cm or 24") + Ring Fitting	20 2900 20 20 12						•		•		4
Single Pick-up Pipe 4.0mm (41 cm or 16")	5520001							•	•		5
Fuel Pick-up pipe 4mm W/FTNG 19.5" - Vent fitting 1/2" NPT	20 2900 20 40 06						•		•		9
Single Pick-up Pipe 4.0mm with Return	20 2900 20 20 59									•	6
Fuel Pick-up pipe 2mm W/FTNG 24.5 inches - Vent fitting 1/2" NPT	20 2900 20 20 04	•	•	•	•	•		•			9
Compression Fitting 1/4" NPT	20 2900 20 20 44	•	•	•	•	•	•	•	•	•	8
Compression Fitting 3/8" NPT	5520002	•	•	•	•	•	•	•	•	•	8
Compression Fitting 1/2" NPT	5520006	•	•	•	•	•	•	•	•	•	
Rubber Seal Ring for Fuel Pick-up Pipe	20 2900 20 20 26	•	•	•	•	•	•	•	•		7
Compression FTNG 3/4" NPT	20 2900 20 20 82	•	•	•	•	•	•	•	•	•	8
Compression FTNG 9/16" w/O-ring	5520007	•	•	•	•	•	•	•	•	•	
Automotive Fuel Pick-up Assembly	22 1000 20 11 00	•	•	•	•	•		•			10

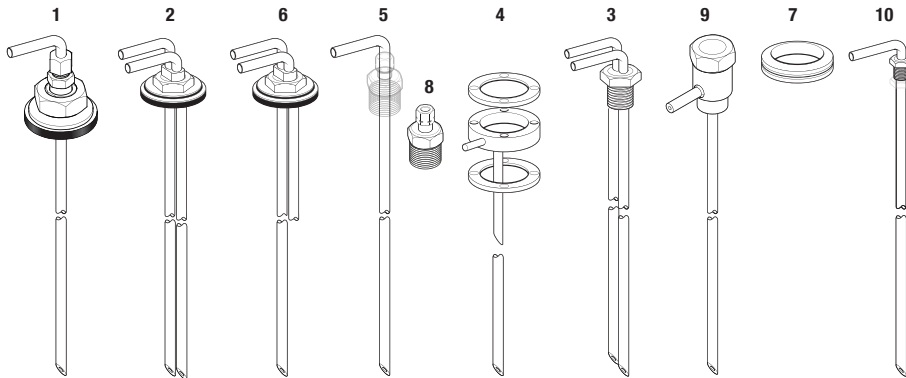

Black Plastic Fuel Line 2.0mm ID	890 31 125	•	•	•	•	•	•	•	•		per mtr
White Plastic Fuel Line 1.5mm ID	890 31 118	•	•	•	•	•	•	•	•		per mtr
White Plastic Fuel Line 2.0mm ID	890 31 055	•	•	•	•	•	•	•	•		per mtr
Black Rubber Fuel Line 3.5mm ID	360 75 300	•	•	•	•	•	•	•	•	•	per mtr
Black Rubber Fuel Line 5.0mm ID	360 75 350	•	•	•	•	•	•	•	•	•	per mtr

**NO GRAPHIC**

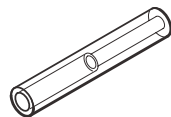

Fuel Line Adapter 3.5mm to 5mm	25 1888 80 01 02							•			
--------------------------------	------------------	--	--	--	--	--	--	---	--	--	--



1  
2  
3

# FUEL SYSTEM

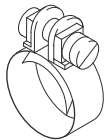
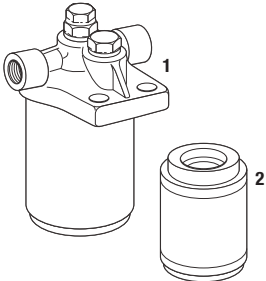
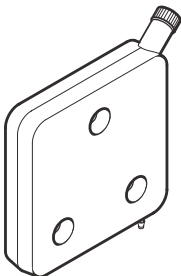
Refer to Fuel System Guide on page 66, to help plan your fuel system.

DESCRIPTION	PART NUMBER	AIRTRONIC D2	AIRTRONIC D4	B1LC compact	B3LC compact	AIRTRONIC D5	D8LC	HYDRONIC 4/5	HYDRONIC 10 / M	HYDRONIC 16/24/30/35	HYDRONIC M-II
Clamp 7mm (used with 360 75 300)	10 2063 00 70 78	•	•	•	•	•	•	•	•	•	•
Clamp 9mm (used with 360 75 300)	10 2068 00 90 98	•	•	•	•	•	•	•	•	•	•
Clamp 10mm (used with 360 75 350)	10 2068 01 00 98	•	•	•	•	•	•	•	•	•	•
Clamp 11mm (used with 360 75 350)	10 2068 01 10 98	•	•	•	•	•	•	•	•	•	•
Clamp 12mm	10 2068 01 20 98	•	•	•	•	•	•	•	•	•	•
Clamp 14mm	10 2068 01 40 98	•	•	•	•	•	•	•	•	•	•
											
Fuel Filter	330 00 052									•	1
Fuel Screen	237 00 054									•	2
											
Plastic Fuel Tank (10L or 2.6 gal - Blue)	22 1000 20 28 00	•	•	•	•	•	•	•	•	•	•
Plastic Cap	22 1000 20 22 00	•	•	•	•	•	•	•	•	•	•
											
Plastic Fuel Filter	25 1226 89 00 37	•	•	•	•	•	•	•	•	•	•
Measuring cylinders 10 ml	552 0004										
Measuring cylinders 25 ml	552 0005										
											

1  
2  
3

# FUEL SYSTEM

Refer to Fuel System Guide on page 66, to help plan your fuel system.

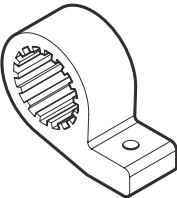
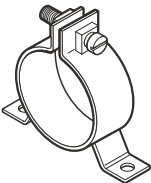
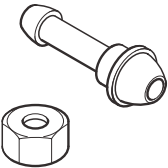
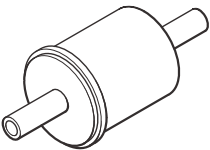
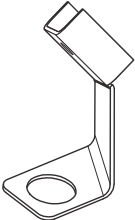
DESCRIPTION	PART NUMBER	AIRTRONIC D2	AIRTRONIC D4	B1LC compact	B3LC compact	AIRTRONIC D5	D8LC	HYDRONIC 4/5	HYDRONIC 10 / M	HYDRONIC 16/24/30/35	HYDRONIC M-II
Clamp 34mm for Fuel Metering Pump	152 00 200	•	•	•	•	•		•			
FMP Holder for Noise Reduction (small pumps)	22 1000 50 03 00	•	•	•	•	•		•			
FMP Holder for Noise Reduction (large pumps)	22 1000 50 07 00	•	•	•	•				•		
											
Fuel Metering Pump Holder	25 1156 20 00 11							•	•		
											
Fuel Connector Nipple and Nut	20 2900 20 20 71									•	
											
Plastic Fuel Filter (installed in front of fuel metering pump)	25 1156 20 00 09	•	•	•	•	•	•	•	•	•	•
											
FMP Bracket <b>RECOMMENDED</b>	20 2900 40 01 04	•	•			•					
											

1  
2  
3

**FUEL SYSTEM** Refer to Fuel System Guide on page 66, to help plan your fuel system.

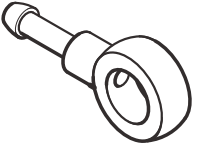
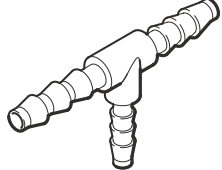
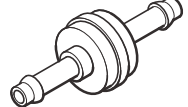
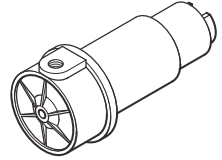
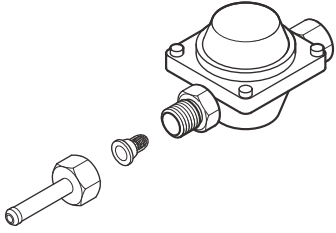
DESCRIPTION	PART NUMBER	AIRTRONIC D2	AIRTRONIC D4	B1LC compact	B3LC compact	AIRTRONIC D5	D8LC	HYDRONIC 4/5	HYDRONIC 10 / M	HYDRONIC 16/24/30/35	HYDRONIC M-II
Bango fitting 8mm	25 1352 88 00 05									•	
											
Fuel T-piece d=4mm, D=8mm	262 31 155							•			
Fuel T-piece d=6mm, D=6mm	262 31 150	•	•	•	•	•	•	•	•	•	•
Fuel T-piece d=6mm, D=8mm	262 31 151	•	•	•	•	•	•	•	•	•	•
Fuel T-piece d=6mm, D=10mm	262 31 152	•	•	•	•	•	•	•	•	•	•
Fuel T-piece d=6mm, D=12mm	262 31 153	•	•	•	•	•	•	•	•	•	•
											
One Way Check Valve 6mm	244 31 060	•	•	•	•	•	•	•	•	•	•
One Way Check Valve 8mm	244 31 061	•	•	•	•	•	•	•	•	•	•
											
Auxiliary fuel Pump 12V	25 1226 89 82 00	•	•	•	•	•	•	•	•	•	•
Auxiliary fuel Pump 24V	25 1226 89 83 00	•	•	•	•	•	•	•	•	•	•
Bango fitting 8mm (2 required)	25 1352 88 00 05									•	
Hollow bolt 8mm (2 required)	104 10 008									•	
Copper seal 8mm (4 required)	323 16 013									•	
											
Pressure Reducer	22 1000 20 08 00	•	•	•	•	•		•			
											

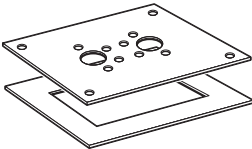
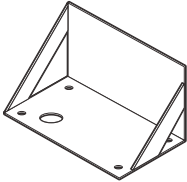
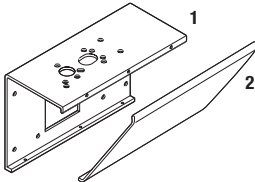
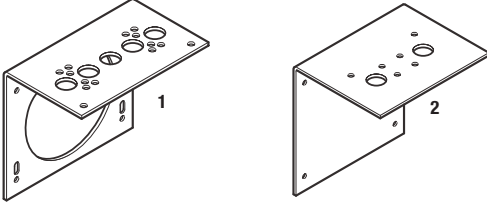
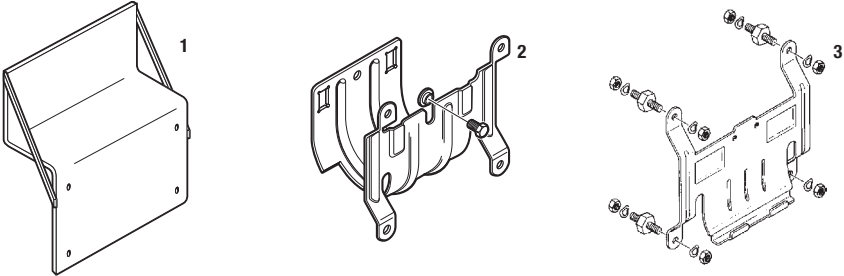

# MOUNTING PARTS

DESCRIPTION	PART NUMBER	AIRTRONIC D2	AIRTRONIC D4	B1LC compact	B3LC compact	AIRTRONIC D5	D8LC	HYDRONIC 4/5	HYDRONIC 10 / M	HYDRONIC 16/24/30/35	HYDRONIC M-II
Mounting Plate with Seal	5540001	•	•	•	•						
											
Side Frame Mounting Tray for Boxed Heaters	20 2900 40 00 57 20 2900 40 00 75								•		◦
											
Cargo Bracket	20 2900 40 00 34	•	•	•	•	•					1
Cargo Bracket Support	20 2900 40 00 35	•	•	•	•	•					2
											
Angle Mounting Bracket	20 2900 40 00 23					•					1
Mounting Bracket	5540016	•	•	•	•						2
											
Inside Frame Mounting Bracket	20 2900 40 00 85							•			1
Saddle Bracketed	25 1864 80 00 01							•			2
Mounting Bracket (model 25 2217 / 2218 / 2219 / 2257)	25 2220 80 00 01							•			3
											

◦ = E-Guardian

1  
2  
3

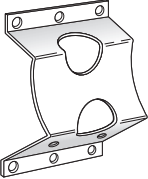
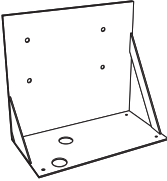
# MOUNTING PARTS

DESCRIPTION	PART NUMBER	AIRTRONIC D2	AIRTRONIC D4	B1LC compact	B3LC compact	AIRTRONIC D5	D8LC	HYDRONIC 4/5	HYDRONIC 10 / M	HYDRONIC 16/24/30/35	HYDRONIC M-II
Mounting Bracket for Coolant Pump	25 1371 25 00 01									•	
											
"L" Bracket for HYDRONIC 5 Box only (used with Cross Frame Mounting Bracket 20 2900 40 00 22)	20 2900 40 01 03							•			
											
Mounting Bracket	25 1816 80 00 01							•			
											
Box Base with shock mounts	20 2900 40 90 01							•			2
Box Lid	20 2900 40 00 70							•			2
Box base	25 2800 40 10 02							o		o	
Lid	25 2800 40 10 03							o		o	
Hydronic 5 Box Base	25 2800 40 05 02							•			1
Hydronic 5 Box Lid	25 2800 40 05 01							•			1
Also requires: Silicone Seal - Exhaust	25 1216 88 03 01							•			
Grommet Harness	20 2900 60 10 61							•			
Grommet Fuel	20 1280 09 01 03							•			
Additional bulk head fitting required											

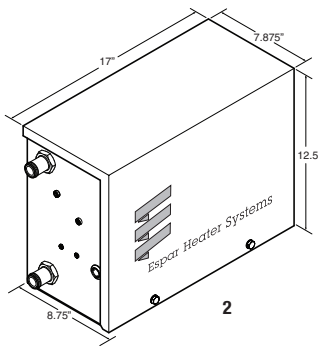
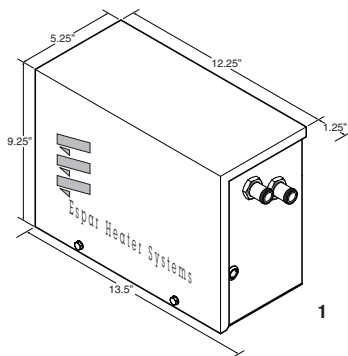





o = E-Guardian

1  
2  
3



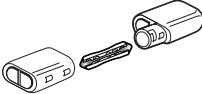
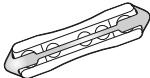



# FUSE HOLDERS, FUSES, BREAKERS

DESCRIPTION	PART NUMBER	AIRTRONIC D2	AIRTRONIC D4	B1LC compact	B3LC compact	AIRTRONIC D5	D8LC	HYDRONIC 4/5	HYDRONIC 10 / M	HYDRONIC 16/24/30/35	HYDRONIC M-II
Holder for Ceramic Fuse with 16 AMP Fuse	204 00 099	•	•	•	•	•	•	•	•	•	
											
Ceramic 25 AMP Fuse	204 21 009	•	•	•	•	•	•	•	•	•	
											
Water-proof Fuse Holder Cover	2199984	•	•	•	•	•	•	•	•	•	
											
Bussman BAF 30 AMP Fuse	5670050	•	•	•	•	•	•	•	•	•	
Fuse T6 3 AMP for Thermostat	460 26 001							•	•		
											
Packard ATC Fuse Holder with Terminals	5670051	•	•	•	•	•	•	•	•	•	
Base, Fuse Holder 12033769	20 2900 70 70 17	•	•	•	•	•	•	•	•	•	
Cover, Fuse Holder 12033731	20 2900 60 70 09	•	•	•	•	•	•	•	•	•	
Terminal 12033997L	5670199	•	•	•	•	•	•	•	•	•	
											
ATC 3 AMP Fuse	5670057	•	•	•	•	•	•	•	•	•	
ATC 5 AMP Fuse	204 00 079				•			•			
ATC 10 AMP Fuse	5670056	•	•	•	•	•	•	•	•	•	
ATC 15 AMP Fuse	5670053	•	•	•	•	•	•	•	•	•	
ATC 20 AMP Fuse	5670055	•	•	•	•	•	•	•	•	•	
ATC 25 AMP Fuse	204 00 089	•	•	•	•	•	•	•	•	•	
ATC 30 AMP Fuse	5670054	•	•	•	•	•	•	•	•	•	
											

1  
2

1  
2  
3

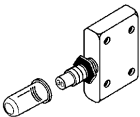
# FUSE HOLDERS, FUSES & BREAKERS

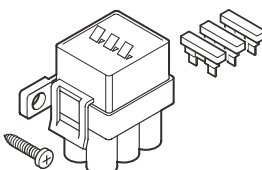
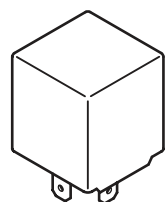
DESCRIPTION	PART NUMBER	AIRTRONIC D2	AIRTRONIC D4	B1LC compact	B3LC compact	AIRTRONIC D5	D8LC	HYDRONIC 4/5	HYDRONIC 10 / M	HYDRONIC 16/24/30/35	HYDRONIC M-II
Breaker 30 Amp (D7WB)	5670059	•	•	•	•	•	•	•	•	•	
Breaker 25 Amp (D5WB-oldstyle)	5670046	•	•	•	•	•	•	•	•	•	
											
Fuse Holder Base	204 31 004	•	•	•	•	•	•	•	•	•	1
Fuse Holder Cover	204 31 005	•	•	•	•	•	•	•	•	•	2
											
Fuse Holder Kit 5A, 15A, 25A	22 1000 31 06 00	•	•	•	•	•	•	•	•	•	
INCLUDES: Fuses and Terminals											
											
Relay 24 volt (D1L/D3L/V7S/D12W)	203 00 066						•	•			
											

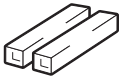
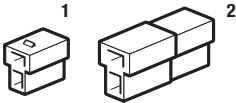
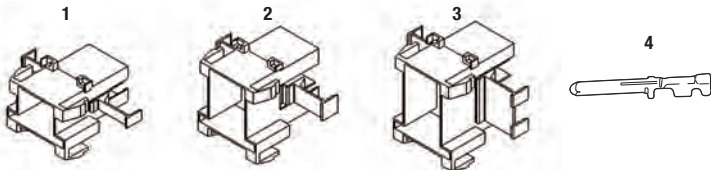
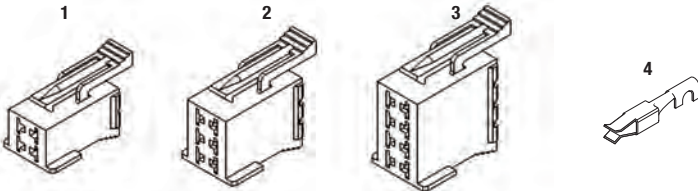

# TERMINALS AND CONNECTORS

DESCRIPTION	PART NUMBER	AIRTRONIC D2	AIRTRONIC D4	B1LC compact	B3LC compact	AIRTRONIC D5	D8LC	HYDRONIC 4/5	HYDRONIC 10 / M	HYDRONIC 16/24/30/35	HYDRONIC M-II
Rubber Boot for Fuel Metering Pump	320 31 120	•	•	•	•	•	•	•	•	•	
											
Plug and Socket Connector	206 00 040	•	•	•	•	•	•	•	•	•	
											
Socket Housing, Male 2 Pin "T"	206 00 099	•	•	•	•	•	•	•	•	•	1
Socket Housing, Female 2 Pin "T"	206 31 004	•	•	•	•	•	•	•	•	•	2
											
Socket Housing, Female 4 Pin	206 31 100	•	•	•	•	•	•	•	•	•	1
Socket Housing, Female 6 Pin	206 31 106	•	•	•	•	•	•	•	•	•	2
Socket Housing, Female 8 Pin	206 31 101	•	•	•	•	•	•	•	•	•	3
Terminal, Male AWG 16-20	206 36 018	•	•	•	•	•	•	•	•	•	4
											
Socket Housing, Male 4 Pin	206 31 296	•	•	•	•	•	•	•	•	•	1
Socket Housing, Male 6 Pin	206 31 297	•	•	•	•	•	•	•	•	•	2
Socket Housing, Male 8 Pin	206 31 298	•	•	•	•	•	•	•	•	•	3
Terminal, Female AWG 16-20	206 73 052	•	•	•	•	•	•	•	•	•	4
											

# TERMINALS AND CONNECTORS

DESCRIPTION	PART NUMBER
Socket Housing, Female 2 Pin for Sensor	206 31 018
Socket Housing, Male 2 Pin for Sensor	206 31 306
Socket Housing, 2 Pin with Spring (FMP Connection)	206 31 290
Mini Terminal, Female AWG 16-20	206 00 180
Socket Housing M Stribel Control	206 31 319
Plug for 206 31 319 Stribel	206 75 042

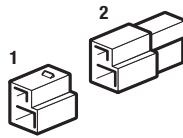

Fuel Metering Pump Housing Kit INCLUDES: terminals and seals.	22 1000 31 87 00
--	------------------

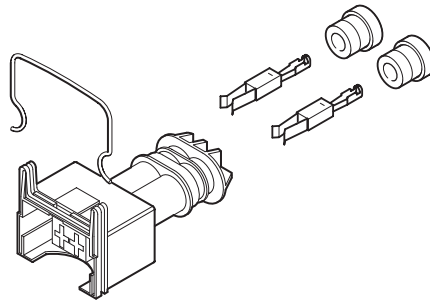

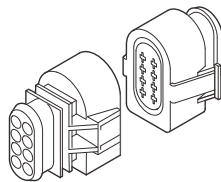

Hydronic 4/5 Main harness connector Kit	22 1000 30 10 21
---	------------------



AIRTRONIC D2	AIRTRONIC D4	B1LC compact	B3LC compact	AIRTRONIC D5	D8LC	HYDRONIC 4/5	HYDRONIC 10 / M	HYDRONIC 16/24/30/35	HYDRONIC M-II
•		•							
•	•	•	•						
•	•					•	•	•	
•	•					•	•	•	
							•		
							•		

1  
2  
3

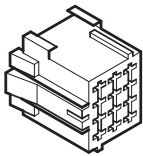
# TERMINALS AND CONNECTORS

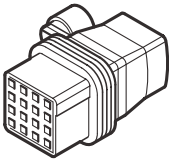
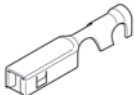
DESCRIPTION	PART NUMBER	AIRTRONIC D2	AIRTRONIC D4	B1LC compact	B3LC compact	AIRTRONIC D5	D8LC	HYDRONIC 4/5	HYDRONIC 10 / M	HYDRONIC 16/24/30/35	HYDRONIC M-II
7 day timer 12 pin connector housing	206 31 293	•	•	•	•	•	•	•	•	•	•
											
Mini terminal, female AwG 16-20	206 00 180	•	•	•	•	•	•	•	•	•	•
											
Hydronic M square connector housing	206 31 319									•	•
Hydronic M square connector w/pins	22 1000 31 93 00									•	•
											
Mini terminal Stribel AwG 16-20	206 36 154									•	•
											

## POWER CONVERTERS 12V TO 24V

DESCRIPTION	PART NUMBER
Power Converter 12 - 24 288W	5673401



12V to 24V Power Converter Asmbly 3601	25 2800 90 12 24
12V to 24V Power Harness for 5673601	25 2800 70 16 00
Power Converter 12 - 24 488W	5673601



Heat sink	20 2900 40 00 04
-----------	------------------

**NO  
GRAPHIC**

1  
2  
3

**NOTES:**

1

2

3

# EXHAUST

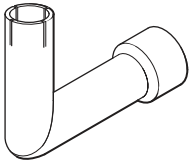
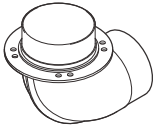
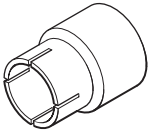
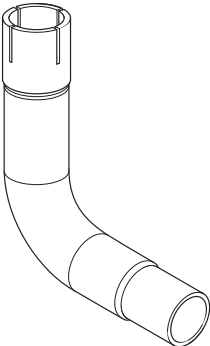

DESCRIPTION	PART NUMBER	AIRTRONIC D2	AIRTRONIC D4	B1LC compact	B3LC compact	AIRTRONIC D5	D8LC	HYDRONIC 4/5	HYDRONIC 10 / M	HYDRONIC 16/24/30/35	HYDRONIC M-II
Elbow (with 30mm flex exhaust)	25 1226 89 55 00	•	•	•	•	•		•			
											
Exhaust Elbow (with exhaust)	22 1000 40 03 00									•	
											
Straight Exhaust Fitting (24-30mm)	25 1520 80 01 01	•	•	•	•	•		•			
Straight Exhaust Fitting (30-28mm)	25 1226 89 00 28								•		•
Straight Exhaust Fitting (30-26mm)	25 1226 89 00 29								•		•
											
Exhaust 90° adapter (30mm)	25 2800 30 10 00								•		•
											

1  
2  
3

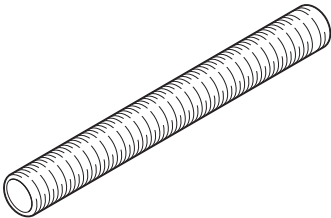
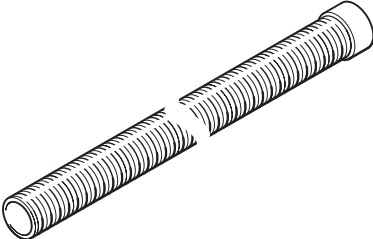
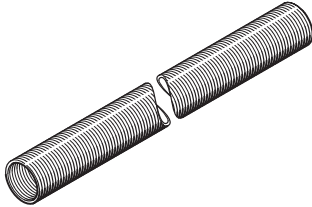
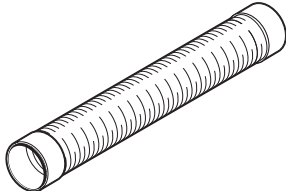
# EXHAUST

DESCRIPTION	PART NUMBER	AIRTRONIC D2	AIRTRONIC D4	B1LC compact	B3LC compact	AIRTRONIC D5	D8LC	HYDRONIC 4/5	HYDRONIC 10 / M	HYDRONIC 16/24/30/35	HYDRONIC M-II	
Flexible Stainless Steel Exhaust 24mm (1.3 mtr) <span style="background-color: yellow;">RECOMMENDED</span>	360 61 557	•	•	•	•	•		•				each
												
Flexible Stainless Steel Exhaust 24mm x 1.3M with end cap	25 1774 80 02 00	•	•	•	•	•		•				
Flexible Stainless Steel Exhaust 30mm x 1.3M with end cap	25 1816 80 08 00								•		•	
												
Flexible Stainless Steel Exhaust 40mm (when elbow is used)	5530012							•				per mtr
Flexible Stainless Steel Exhaust 42mm (direct connect)	5530013							•				per mtr
Flexible Stainless Steel Exhaust 24mm (one layer) <span style="background-color: yellow;">RECOMMENDED</span>	360 61 550	•	•	•	•	•		•				per mtr
Flexible Stainless Steel Exhaust 24mm (two layer)	360 61 299	•	•	•	•	•		•				per mtr
Flexible Stainless Steel Exhaust 30mm (one layer)	360 61 580								•		•	per mtr
Flexible Stainless Steel Exhaust 30mm (two layers)	360 61 300	•	•	•	•	•			•		•	per mtr
												
Flexible Stainless Steel Exhaust 70mm (direct connect)	5530015									•		per mtr
												

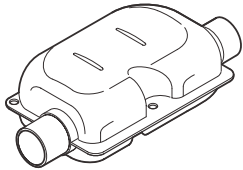
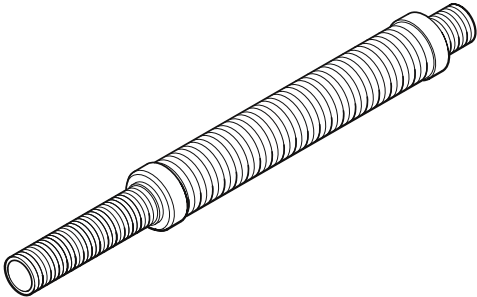
# EXHAUST

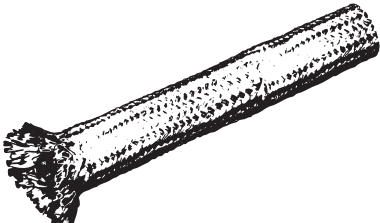
DESCRIPTION	PART NUMBER	AIRTRONIC D2	AIRTRONIC D4	B1LC compact	B3LC compact	AIRTRONIC D5	D8LC	HYDRONIC 4/5	HYDRONIC 10 / M	HYDRONIC 16/24/30/35	HYDRONIC M-II
Exhaust Muffler for 24mm (Slimmer-New)	22 1000 40 09 00	•	•	•	•	•		•			
Exhaust Muffler for 24mm (Wider-Old)	25 1864 81 01 00	•	•	•	•	•		•			
											
Exhaust Muffler 30mm	25 1226 89 58 00	•	•	•	•	•					
											
Exhaust Muffler 30mm	25 1806 80 01 00								•		•
											
Exhaust Insulation Sock 1" for 22mm-24mm ID Exhaust	5530001	•	•	•	•			•			per ft.
Exhaust Insulation Sock 2" for 24mm-42mm ID Exhaust	5530002	•	•	•	•	•	•	•			per ft.
Exhaust Insulation Sock 3" for 70mm ID Exhaust	5530003									•	per ft.
											

1  
2  
3

# EXHAUST

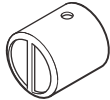
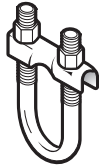
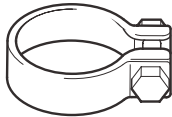
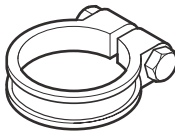
DESCRIPTION	PART NUMBER	AIRTRONIC D2	AIRTRONIC D4	B1LC compact	B3LC compact	AIRTRONIC D5	D8LC	HYDRONIC 4/5	HYDRONIC 10 / M	HYDRONIC 16/24/30/35	HYDRONIC M-II
Exhaust End Cap for 24mm	25 1482 80 00 01	•	•	•	•	•		•			
											
Plastic Air Intake End Cap with Crossbar 20mm	25 1688 80 12 01			•				•			
Exhaust End Cap with Crossbar 24mm	20 2900 30 24 00	•	•	•	•	•		•			
Plastic Air Intake End Cap with Crossbar 25mm	25 1729 89 00 02	•	•		•	•					
Exhaust End Cap with Crossbar 30mm	25 1785 80 02 00								•		•
Exhaust End Cap with Crossbar 46mm	22 1000 40 02 00						•				
											
Exhaust Clamp for 70mm	5530004										•
											
Clamp for Exhaust Pipe 26mm	152 61 102	•	•	•	•	•		•			
											
Clamp for Exhaust Pipe 27mm-30mm	152 09 002								•		•
Clamp for Exhaust Pipe 30mm-33mm	152 09 003								•		•
Clamp for Exhaust Pipe 32mm-50mm	152 09 004						•				
											





**DUCTING** Air ducting is critical to the performance of your heater - for information on how to layout a system and measure restriction values see the Rating Guide on page 67

DESCRIPTION	PART NUMBER
90° Air Outlet Hood 60mm Outlet	22 1000 01 00 20
90° Air Outlet Hood 75mm Outlet	22 1000 01 00 22
90° Air Outlet Hood 90mm Outlet	22 1000 01 00 23
90° Air Outlet Hood 60mm Outlet	25 1688 89 01 01
90° Air Outlet Hood 75mm Outlet	22 1000 01 00 02
90° Air Outlet Hood 90mm Outlet	25 1729 89 10 00

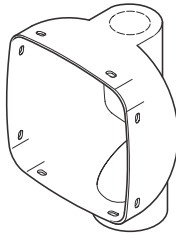

Air Intake Hood (60mm or 2.4")	22 1000 40 06 00
--------------------------------	------------------

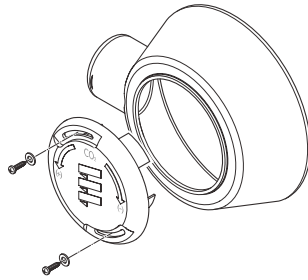

Adapter Ring di=60mm, da=75mm	22 1000 01 00 08
Adapter Ring di=75mm, da=90mm	25 1822 89 00 01
Adapter Ring di=90mm, da=100mm	20 1607 80 00 01

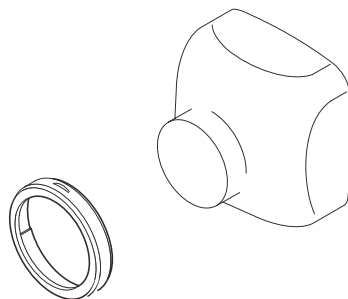

AIRTRONIC D2	AIRTRONIC D4	B1LC compact	B3LC compact	AIRTRONIC D5	D8LC	HYDRONIC 4/5	HYDRONIC 10 / M	HYDRONIC 16/24/30/35	HYDRONIC M-II
•									
	•								
	•								
		•							
			•						
				•					
								•	
•		•							
•	•	•	•						
	•		•	•					

1  
2  
3

**DUCTING** Air ducting is critical to the performance of your heater - for information on how to layout a system and measure restriction values see the Rating Guide on page 67

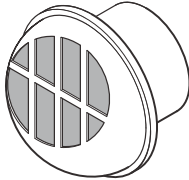
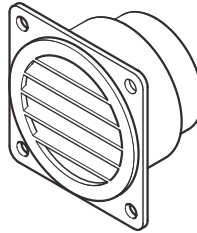
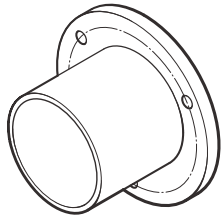
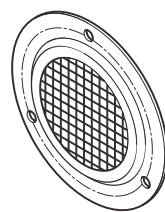
DESCRIPTION	PART NUMBER	AIRTRONIC D2	AIRTRONIC D4	B1LC compact	B3LC compact	AIRTRONIC D5	D8LC	HYDRONIC 4/5	HYDRONIC 10 / M	HYDRONIC 16/24/30/35	HYDRONIC M-II
Deflector (60mm or 2.4")	20 2800 50 02 00	•	•	•	•	•					
Deflector (50mm or 2")	20 1575 80 08 00	•	•	•	•	•	•				
											
Adjustable Grille (75-100mm or 3-4")	22 1050 89 21 00	•	•	•	•	•	•	•	•	•	•
Adjustable Grille (90-100mm or 3.5-4")	20 1609 80 09 00		•		•	•					
											
Hose Flange for Outlet Grille for Duct Size 50mm (2")	20 1575 80 08 01	•	•	•	•	•	•				
Hose Flange for Outlet Grille for Duct Size 60mm (2.4")	20 1577 89 06 01	•	•	•	•	•					
Hose Flange for Outlet Grille for Duct Size 75mm (3")	25 1226 89 00 12	•	•	•	•	•	•				
Hose Flange for Outlet Grille for Duct Size 90mm (3.5")	20 1297 00 00 01	•	•	•	•	•	•				
Hose Flange for Outlet Grille for Duct Size 100mm (4")	25 1226 89 00 40	•	•	•	•	•	•				
											
Black Open Screen (60mm or 2.4")	22 1000 01 00 01	•	•	•	•	•					
Black Open Screen (90mm or 3.5")	20 1465 89 05 00	•	•	•	•	•					
Black Open Screen (140mm or 5.25")	25 1729 89 00 05	•	•	•	•	•					
Nickel Plated Open Screen (140mm or 5.25")	25 1226 89 05 00	•	•	•	•	•					
											

**DUCTING** Air ducting is critical to the performance of your heater - for information on how to layout a system and measure restriction values see the Rating Guide on page 67

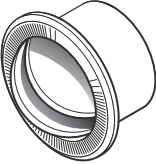
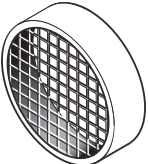
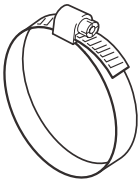
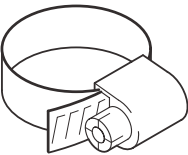
DESCRIPTION	PART NUMBER	AIRTRONIC D2	AIRTRONIC D4	B1LC compact	B3LC compact	AIRTRONIC D5	D8LC	HYDRONIC 4/5	HYDRONIC 10 / M	HYDRONIC 16/24/30/35	HYDRONIC M-II
French Closeable Outlet with Flange (75mm or 3" Ducting)	330 31 311	•	•	•	•	•	•				
											
Air Inlet Safety Screen (60mm or 2.4")	25 1688 80 06 00	•		•							
Air Inlet Safety Screen (75mm or 3")	25 1552 05 01 00	•	•		•						
Air Inlet Safety Screen (90mm or 3.5")	25 1729 80 00 01		•		•	•					
Air Inlet Safety Screen (100mm or 4")	25 1226 89 44 00						•				
											
Stainless Steel Hose Clamp 33-57mm (50mm or 2" Ducting)	5550001	•	•	•	•	•	•				
Stainless Steel Hose Clamp 46-70mm (60mm or 2.4" Ducting)	5550004			•	•	•	•				
Stainless Steel Hose Clamp 59-83mm (75mm or 3" Ducting)	5550002	•	•	•	•	•	•				
Stainless Steel Hose Clamp 84-108mm (100mm or 4" Ducting)	5550003			•	•	•	•				
											
Ducting Clamp 32-50mm	10 2067 03 20 50	•	•	•	•	•	•	•	•	•	•
Ducting Clamp 33-57mm	5550001	•	•	•	•	•	•	•	•	•	•
											

1  
2  
3

**DUCTING** Air ducting is critical to the performance of your heater - for information on how to layout a system and measure restriction values see the Rating Guide on page 67

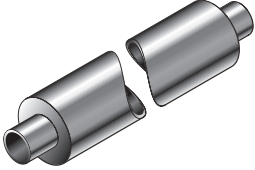
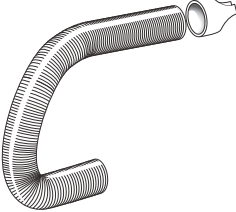
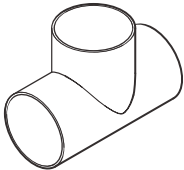
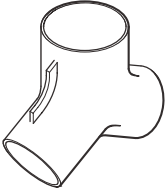
DESCRIPTION	PART NUMBER	AIRTRONIC D2	AIRTRONIC D4	B1LC compact	B3LC compact	AIRTRONIC D5	D8LC	HYDRONIC 4/5	HYDRONIC 10 / M	HYDRONIC 16/24/30/35	HYDRONIC M-II
Air Intake Silencer (75mm or 3")	25 1226 89 15 00	•	•	•	•						
Air Intake Silencer (100mm or 4")	25 1226 89 56 00		•		•	•	•				
											
Combustion Air Intake Flex Hose 30mm ID	10 2114 25 00 00						•				
End Cap	25 1480 89 04 00						•				
											
Plastic "T" Piece 60mmx60mmx60mm or 2.4"x2.4"x2.4"	25 1688 89 00 02	•		•							
Metal "T" Piece 75mmx75mmx75mm or 3"x3"x3"	25 1482 89 07 00	•	•	•	•	•	•				
											
Plastic "Y" Piece D=60mm, d=50mm	25 1688 89 00 03	•		•							
Metal "Y" Piece D=75mm, d=50mm	25 1482 80 08 00	•	•	•	•	•	•				
											

per mtr

**DUCTING** Air ducting is critical to the performance of your heater - for information on how to layout a system and measure restriction values see the Rating Guide on page 67

DESCRIPTION	PART NUMBER
Plastic Reducer di=60mm, D=75mm	25 1688 89 00 10
Plastic Reducer di=75mm, D=100mm	25 1226 89 00 47
Plastic Reducer di=75mm, D=50mm	25 1226 89 00 46
Plastic Reducer di=75mm, D=60mm	25 1226 89 00 50
Plastic Reducer di=100mm, D=50mm	25 1226 89 00 48

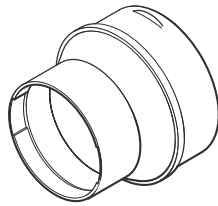

Operating Cable for 330 00 174	REQUIRES air regulating valve	22 1000 01 03 00
--------------------------------	-------------------------------	------------------

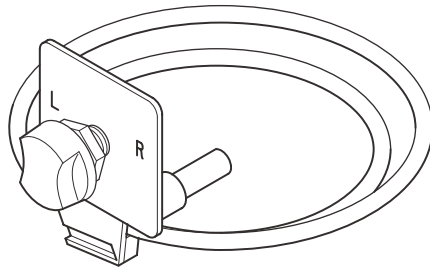

Air Regulating Valve 60mm		330 00 174
Air Regulating Valve 90mm	REQUIRES operating cable	330 00 175

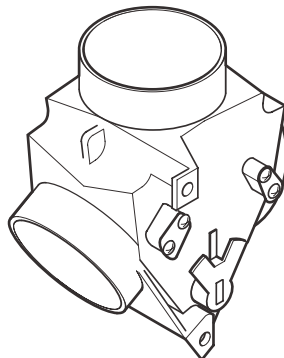

AIRTRONIC D2	AIRTRONIC D4	B1LC compact	B3LC compact	AIRTRONIC D5	D8LC	HYDRONIC 4/5	HYDRONIC 10 / M	HYDRONIC 16/24/30/35	HYDRONIC M-II
•	•	•	•	•					
•	•	•	•	•	•				
•	•	•	•	•					
•	•	•	•	•	•				
	•	•	•	•	•				

1  
2  
3

# COOLANT PUMPS

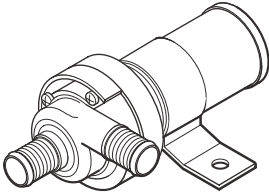
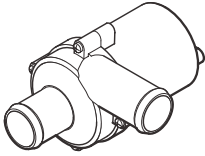
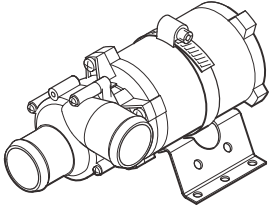
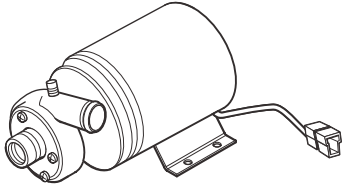
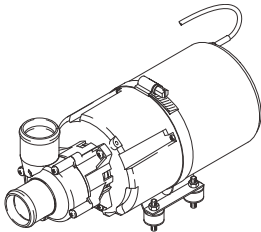
DESCRIPTION	PART NUMBER	AIRTRONIC D2	AIRTRONIC D4	B1LC compact	B3LC compact	AIRTRONIC D5	D8LC	HYDRONIC 4/5	HYDRONIC 10 / M	HYDRONIC 16/24/30/35	HYDRONIC M-II
Coolant Pump (700 L/hr) 12 volt	25 1815 25 01 00								•		
Coolant Pump (700 L/hr) 24 volt	25 1816 25 01 00								•		
											
Coolant Pump (800 L/hr) 12 volt	25 2275 25 00 00							•			
Coolant Pump (900 L/hr) 24 volt	25 2009 25 00 00							•			
											
Flowtronic Coolant Pump (5000 L/hr) 24 volt	25 1818 29 00 00									•	
											
High Capacity Pump 12 volt Albany (2280 L/hr)	20 2900 60 01 39								•		•
High Capacity Pump 24 volt Albany (2280 L/hr)	20 2900 70 01 40								•		•
											
Flowtronic Coolant Pump 24 volt (6000 L/hr)	25 1818 27 00 00									•	
											

# PLUMBING

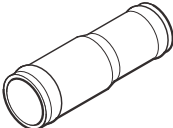
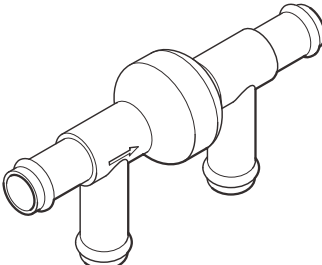
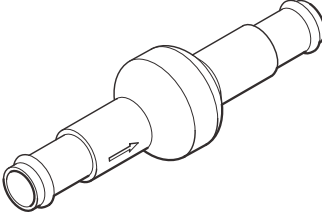
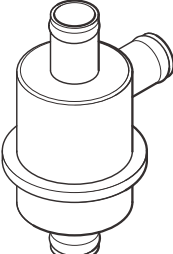
DESCRIPTION	PART NUMBER	AIRTRONIC D2	AIRTRONIC D4	B1LC compact	B3LC compact	AIRTRONIC D5	D8LC	HYDRONIC 4/5	HYDRONIC 10 / M	HYDRONIC 16/24/30/35	HYDRONIC M-II
Brass Reducer D= 18mm, d= 15mm	20 1645 80 02 01							•	•		•
Brass Reducer D= 20mm, d= 18mm	20 1645 89 00 06							•	•		•
											
One Way Check Valve D= 18mm, d= 18mm	254 00 070							•	•		•
One Way Check Valve D= 20mm, d= 18mm	254 00 073							•	•		•
One Way Check Valve D= 20mm, d= 20mm	254 00 074							•	•		•
											
One Way Check Valve 20mm	254 00 072							•	•		•
											
Brass Water Thermostat D= 18mm, d= 18mm (70oC-75oC) 158oF-167oF	330 00 123							•	•		•
Brass Water Thermostat D= 20mm, d= 20mm (70oC-75oC) 158oF-167oF	330 00 124							•	•		•
											

# PLUMBING

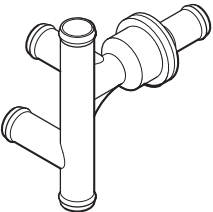
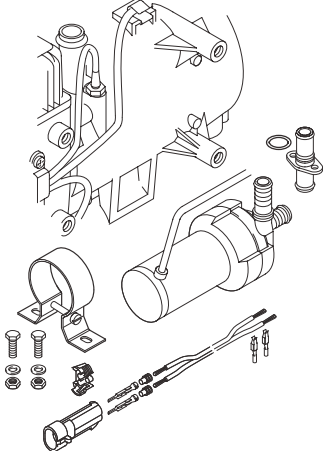
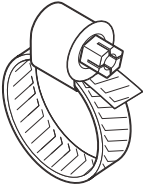
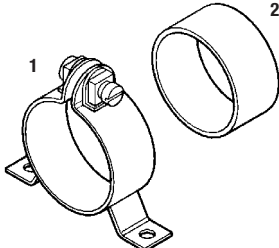
DESCRIPTION	PART NUMBER	AIRTRONIC D2	AIRTRONIC D4	B1LC compact	B3LC compact	AIRTRONIC D5	D8LC	HYDRONIC 4/5	HYDRONIC 10 / M	HYDRONIC 16/24/30/35	HYDRONIC M-II
5 Way Valve with Thermostat	25 2014 80 72 00							•	•	•	•
											
Conversion Kit for Water Pump	22 1000 10 01 00								•		
											
Clamp 16-25mm ID 10	10 2067 01 60 25	•	•	•	•	•	•	•	•	•	•
Clamp 20-32mm ID 10	22 2065 02 00 32	•	•	•	•	•	•	•	•	•	•
											
Pump Clamp 48mm 22	22 1000 50 10 00						•	•			1
Rubber Ring for Large FMP	20 1449 00 10 01						•				2
											

# PLUMBING

DESCRIPTION	PART NUMBER
Brass Pump Fittings 3/4" NPT x 3/4" Barb	20 2900 60 10 02
Brass Pump Fitting 3/4" NPT x 1" Barb	20 2900 60 10 15

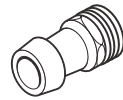

Bulk Head Fitting 3/4" - 2 pieces required 1/2 - 3/4 Straight Barb Connection	20 2900 60 10 10 5520068
Bulk Head Fitting 3/4" to 1"	20 2900 60 10 57

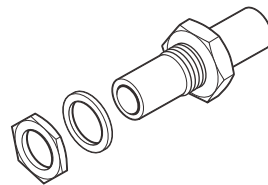

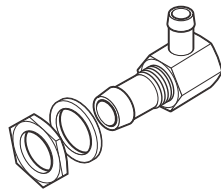

Bulk Head Fitting 3/4" x 90°	20 2900 60 10 37
------------------------------	------------------

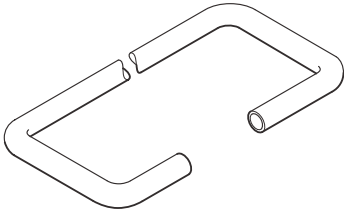
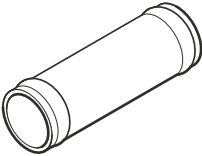

AIRTRONIC D2	AIRTRONIC D4	B1LC compact	B3LC compact	AIRTRONIC D5	D8LC	HYDRONIC 4/5	HYDRONIC 10 / M	HYDRONIC 16/24/30/35	HYDRONIC M-II
						•	•		•
						•	•		•

# PLUMBING

DESCRIPTION	PART NUMBER	AIRTRONIC D2	AIRTRONIC D4	B1LC compact	B3LC compact	AIRTRONIC D5	D8LC	HYDRONIC 4/5	HYDRONIC 10 / M	HYDRONIC 16/24/30/35	HYDRONIC M-II
90o Hose Bend 20mm x 0.29 mtr	20 2900 60 10 23								•		
90o Hose Bend 1.5" ID	5560001									•	
											
180o Coolant Hose 18mm, L = 2000mm	20 1690 81 00 01							•	•		•
180o Coolant Hose 20mm, L = 2000mm	25 1917 80 00 01							•	•		•
											
Brass Hose Connector d= 18mm	20 1528 88 00 03							•	•		•
Brass Hose Connector d= 20mm	20 1534 88 00 01							•	•		•
Brass Hose Connector d= 22mm	20 1645 89 00 07							•	•		•
											
Coolant Hose 1.5" 1mt piece	20 2900 60 10 39							•			
											

## FUEL SYSTEM GUIDE

This guide is to help in selecting which size fuel line, rubber hose and clamps are required for a specific heating system. Refer to the Fuel System section of this manual for specific part numbers.

Cross-reference this information with the corresponding heater manual for maximum height and length specifications.

**AIRTRONIC 2**  
**AIRTRONIC 4**  
**B1LC compact**  
**B3LC compact**  
**D/B5LC**

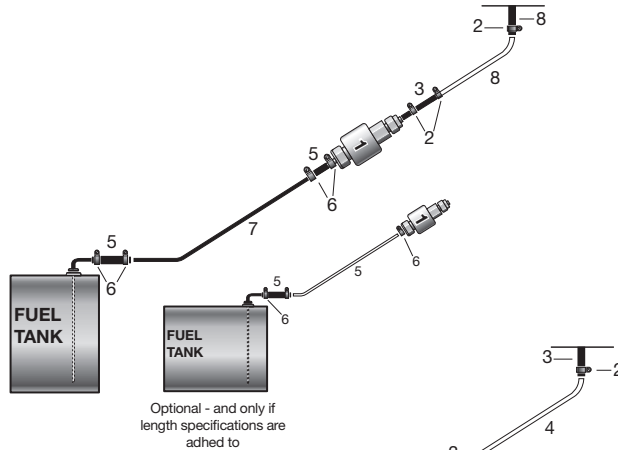

### LEGEND

1. Fuel Pipe Reducer
2. Clamp 9mm
3. Rubber Connector 3.5mm
4. White Plastic Fuel Line 2.0mm
5. Rubber Connector / Fuel Line 5.0mm
6. Clamp 11mm
7. Black Plastic Fuel Line 2.0mm
8. White Plastic Fuel Line 1.5mm

**D8LC**  
**HYDRONIC 10**

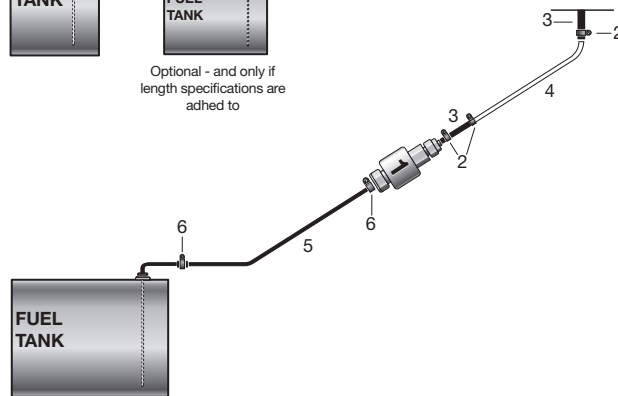

**HYDRONIC 4**  
**HYDRONIC 5**

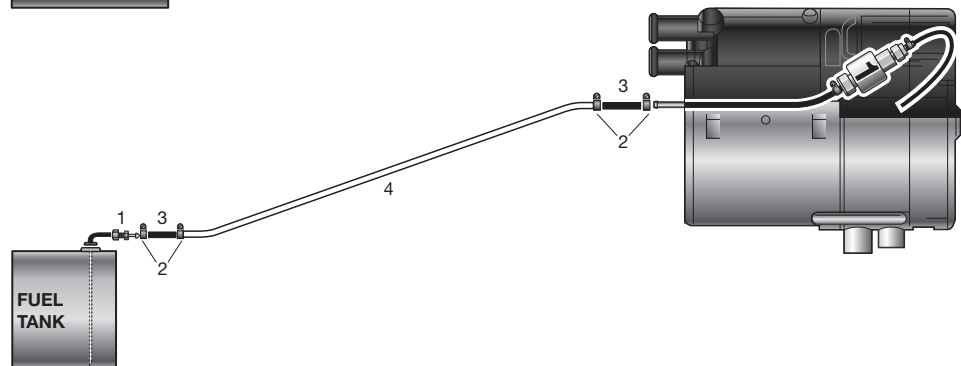

**HYDRONIC 16**  
**HYDRONIC 24**  
**HYDRONIC 30**  
**HYDRONIC 35**

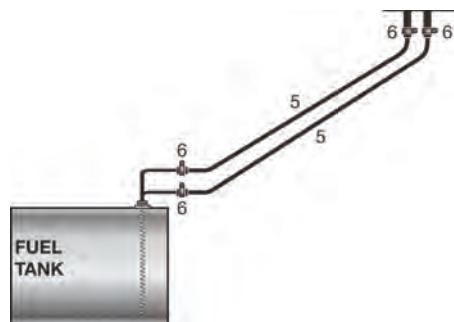

1  
2  
3

## DUCTING RATING GUIDE

### General Tips on Heating Air Ducting and Component Ratings

A heater has the biggest heating air throughput when it can operate with the air blowing freely. Heating air ducting components reduce the throughput. To enable you to check whether or not the installation you plan reduces the air throughput to an inadmissible degree, we have calculated a heater rating for each heater and a component rating for each heating air ducting component:

0 = no temperature increase  
 - = no component rating

The sum of component ratings for the heating air ducting components must not exceed the heater rating, otherwise the outlet temperature will become too high and trigger the safety cutout switch. If the sum of the component ratings exceeds the heater rating, it can be reduced by selecting a larger diameter for the air ducting parts.

### Rule of Thumb:

Double the cross-section or two identical components running parallel = 1/4 of the rating.

#### Example:

50 diameter hose

A = 19.6 cm<sup>2</sup>, R rating 1.0

75 diameter hose

A = 44.2 cm<sup>2</sup>, R rating 0.25

The component rating of smooth welded pipes is only half that of flexible pipe of equal diameter (e.g. double the pipe length).

### Main-line Drawing for 1-duct and 2-duct Heating Air System

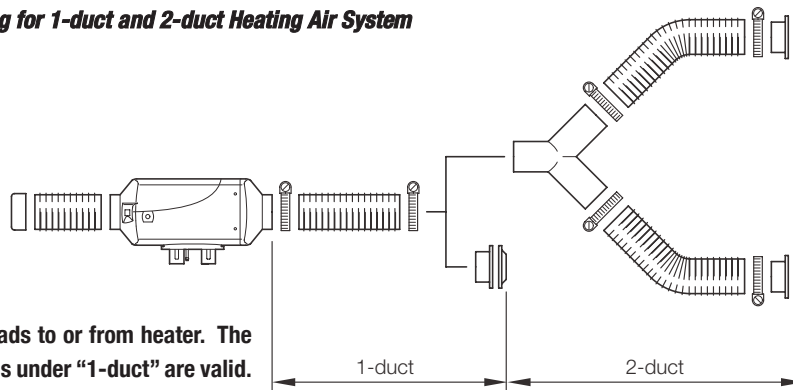

### 1-duct means:

A heating duct leads to or from heater. The component ratings under "1-duct" are valid.

### 2-duct means:

The heating air line branches into two ducts after the heater. Up to the branch the component ratings under "1-duct" are valid, after the branch they fall under "2-duct". If an adjustable outlet is used in the 2-duct heating system, one duct must be unclosable. Note: When determining the sum of the component ratings, do not take the closable duct into consideration.

### Example of Heating Air Ducting for AIRTRONIC D2

Heater Rating = 6

Item	Designation	Component Rating
1	Protective grille	1.7
2	Connection piece 60mm dia.	
3	Flex. pipe, 60mm dia. 0.3m long	0.3
4	Flex. pipe, 60mm dia, 1.0m long	1.0
5	Reduction hood 60mm straight	0
6	1 x 90° bends of flex. pipe	1.2
7	Swivel outlet	1.4
<b>Total Component Rating</b>		<b>5.6</b>

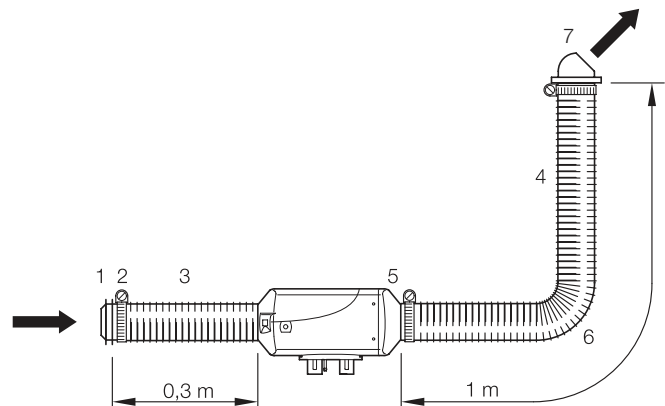

Rating sum = 5.6 and does not exceed the heater rating of 6. The installation is permissible.

1  
2  
3

## DUCTING RATING GUIDE FOR *AIRTONIC D2*

Heater Rating 6 - applies with a 60mm dia. outlet hood.

Heater Rating 12 - applies with a 75mm dia. outlet hood.

The sketch shows how the most important air ducting parts that can be used. They are not intended as examples of installation.

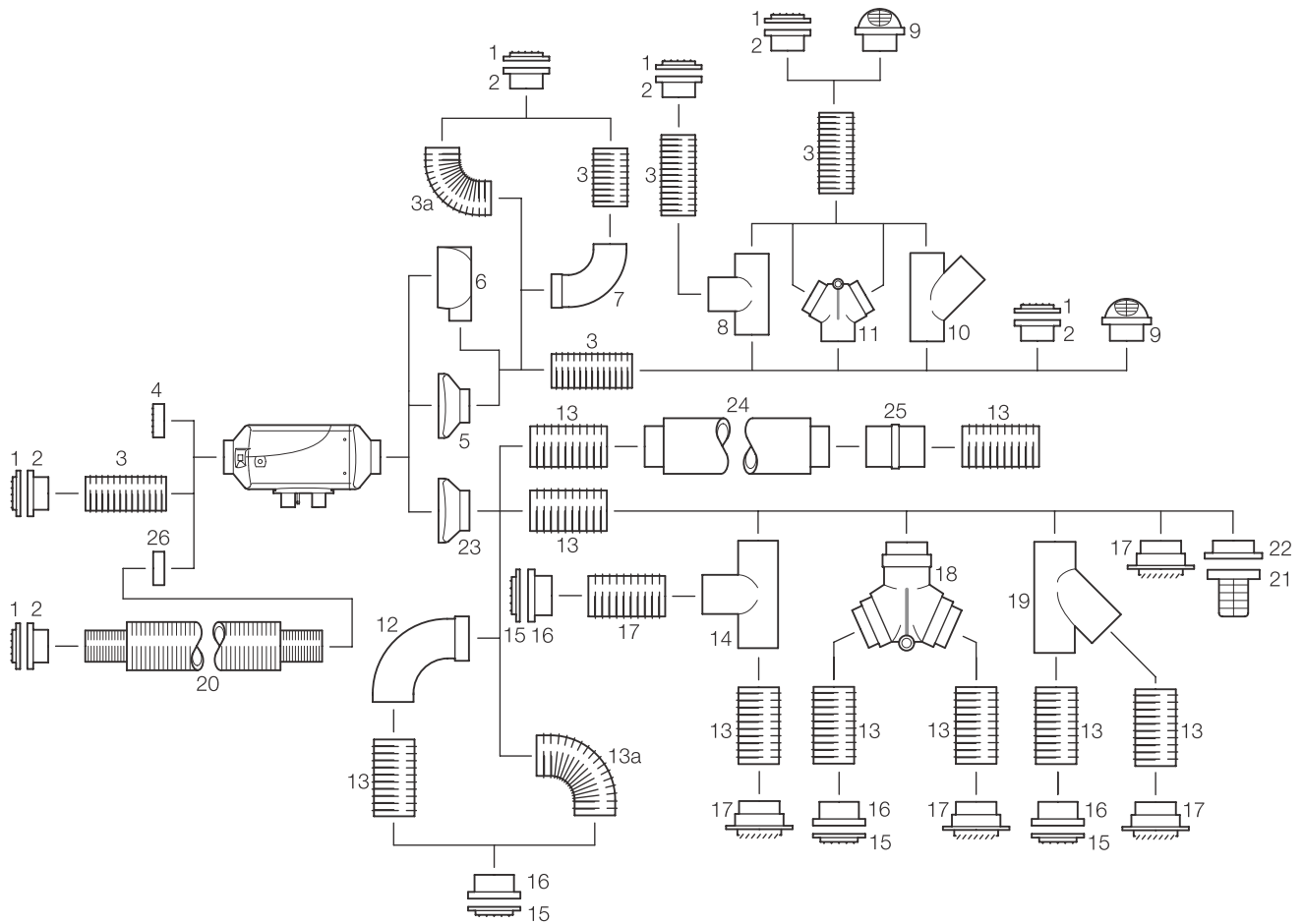

1  
2  
3

## DUCTING RATING GUIDE FOR AIRTRONIC D2

Fig. No.	DESIGNATION  (measurements in millimeters)	COMPONENT RATING		See per No. Air Ducting
		1-duct	2-duct	
	Heating air ducting with reduction hood 60 dia. (heater rating 6)			
1	Grille	1.7	0.6	16
2	connecting socket, plastic			25
3	Flexible pipe, 60 dia. per m	1	0.3	1
3a	90 <sup>0</sup> pipe bend of flex. pip, 60 dia.	1.2	0.8	1
4	Protective grille	0	-	18
5	Reduction hood, 60 dia.	0	-	30
6	Spherical reduction hood, 60 dia.	4.5	-	34
7	90 <sup>0</sup> pipe bend	4.1	0	35
8	T-piece	-	0.6	40
9	Outlet grill 60 dia. (rotatable)	1.4	0	10
10	Y-piece	-	0.3	45
11	Regulating valve 60x60x60 dia. with flap Position "middle" Position "right/left"	- -	0 1	41
	Heating air ducting with reduction hood 75 dia. (heater rating 12)			
12	Pipe bend, 75 dia.	3	0.8	35
13	Flexible pipe, 75 dia. per m	1	0.3	1
13a	90 <sup>0</sup> pipe bend of flex. pipe, 75 dia.	1.2	0.5	1
14	T-piece 75x75x75 dia.	-	0.8	40
15	Grille, 75 dia.	-	-	16
16	Connecting socket, metal, 75 dia.	0.5	0	27
17	Outlet grill (rotatable)	0.4	0	11
18	Regulating valve 75x75x75 dia. with flap Position "middle" Position "right/left"		0.4 1.5	41
19	Y-piece 75x75x75 dia.	-	0.4	45
20	Intake silencer, 75 dia.	0.5	-	4
21	Outlet grill with	0.4	0.4	17
22	Connecting socket, plastic, 75 dia.			17.2
23	Reduction hood, 75 dia.	0	0	30
24	Silencer, 75 dia.	1	-	3
25	Connector, 75 dia.	0.1	-	46
26	Ring, 60x75 dia.	0	-	36

## DUCTING RATING GUIDE FOR AIRTRONIC D4

Heater Rating 3 - applies with a 75mm dia. outlet hood.

Heater Rating 10 - applies with a 90mm dia. outlet hood.

The sketch shows how the most important air ducting parts that can be used. They are not intended as examples of installation.

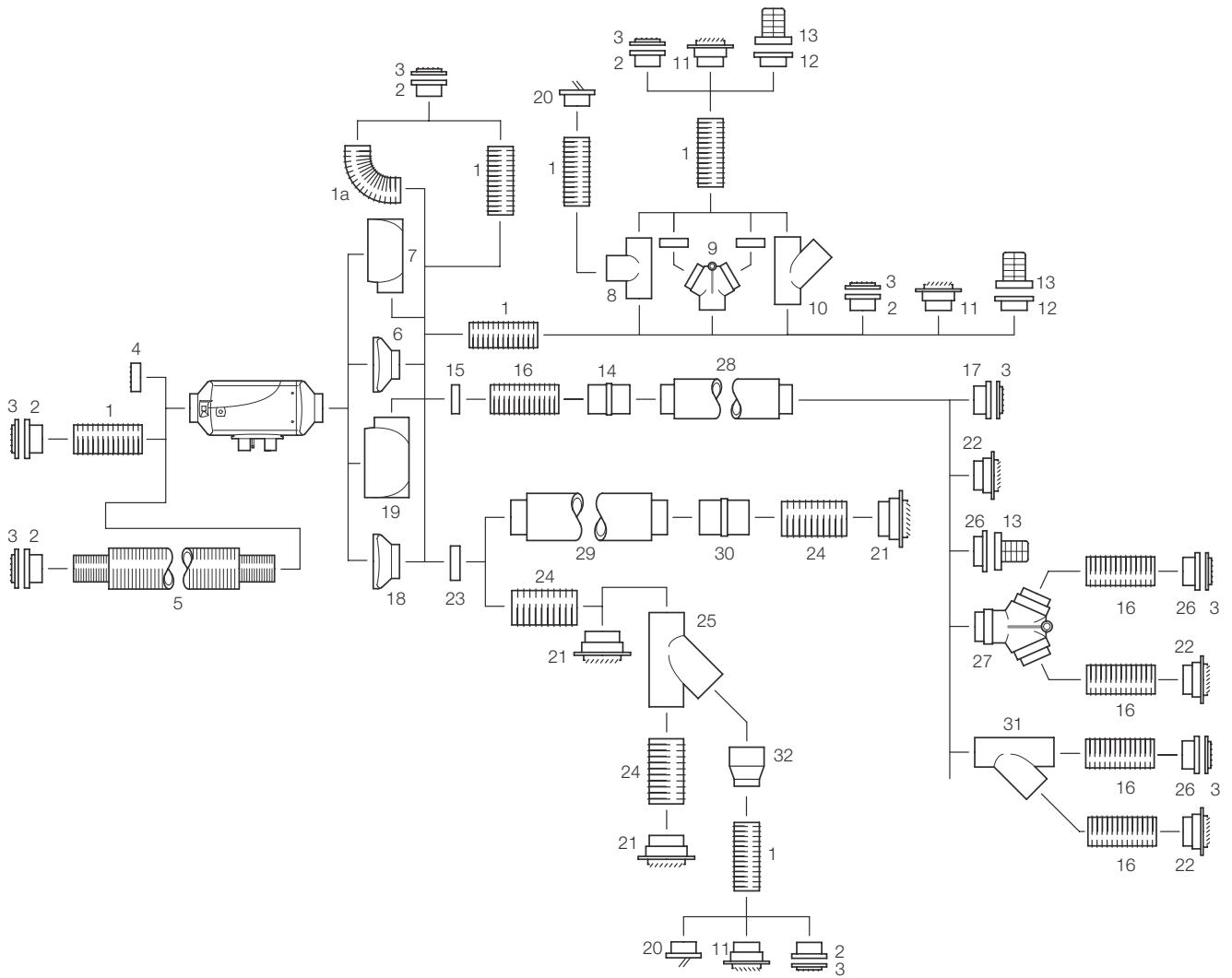

## DUCTING RATING GUIDE FOR AIRTRONIC D4

Fig. No.	DESIGNATION  (measurements in millimeters)	COMPONENT RATING				See per No. Air Ducting
		1-duct		2-duct		
	Heating air ducting with reduction hood 75 dia. (heater rating 3) Heating air ducting with reduction hood 90 dia. (heater rating 10)	75	90	75	90	
1	Flexible pipe, 75 dia. per m	1	-	0.2	0.3	1
1a	90o pipe bend of flex. pipe, 75 dia.	1	-	0.2	0.4	1
2	Connecting socket, metal, 75 dia.	1.4	1.4	-	0.5	27
3	Grille	-	-	-	-	16
4	Grille, 75 dia.	-	-	-	-	18
5	Intake silencer, 75 dia.	1	0.8	-	-	4
6	Reduction hood, 75 dia.	0	-	-	-	30
7	Spherical reduction hood, 75 dia.	2	-	-	-	34
8	T-piece 75x75x75 dia.	-	-	0.3	-	40
9	Regulating valve 75x75x75 dia. with flap Position "middle" Position "right/left"	0	-	-	-	41
		1.3	-	-	-	-
10	Branch piece 75x75x75 dia.	-	-	1.8	-	45
11	Outlet grill (rotatable) 75 dia.	0.6	-	0.5	0.3	11
12	Connector, 75 dia.	-	-	-	-	17.2
13	Outlet grill	1	3.3	0.5	0.5	17
14	Connector, 75 dia.	-	0.1	-	-	46
15	Ring, 75x90 dia.	0	0	-	-	36
16	Flexible pipe, 90 dia. per m	-	1	-	-	1
17	Connector socket, 90 dia. with grille	-	1.4	-	0.5	27
18	Reduction hood, 90 dia.	-	0	-	-	30
19	Spherical reduction hood, 90 dia.	-	5	-	-	34
20	Round outlet, 75 dia.	-	-	-	2.1	12
21	Outlet grill (rotatable) 100 dia.	-	1.4	-	0.5	11
22	Outlet grill (rotatable) 90 dia.	-	2.4	-	0.3	11
23*	Grille, round, 90x100 dia.	-	0	-	-	18
24	Flexible pipe, 100 dia. per m	-	0.6	-	0.4	1
25	Y-piece 100x100x100 dia.	-	-	-	0.5	45
26	Connector, 90 dia., with exhauster pos. 13	-	3.3	-	-	17.2
27	Regulating valve 90x90x90 dia. Position "middle" Position "right/left" - 1.4 - -	-	0	-	-	41
		-	-	-	-	-
28	Silencer, 90 dia.	-	1	-	-	3
29	Silencer, 100 dia.	-	1	-	-	3
30	Connector, 100 dia.	-	0.1	-	-	46
31	Y-piece 90x90x90 dia.	-	-	-	0.5	45
32	Reduction piece, 100 dia. - 75 dia.	-	-	-	0.5	47

\* Pos. 23 - if used as adapter 90x100 dia., cut out the mesh.

1  
2  
3

## DUCTING RATING GUIDE FOR B1LC COMPACT

Heater Rating 6 - applies with a 60mm dia. outlet hood.

Heater Rating 15 - applies with a 75mm dia. outlet hood

The sketch shows how the most important air ducting parts that can be used. They are not intended as examples of installation.

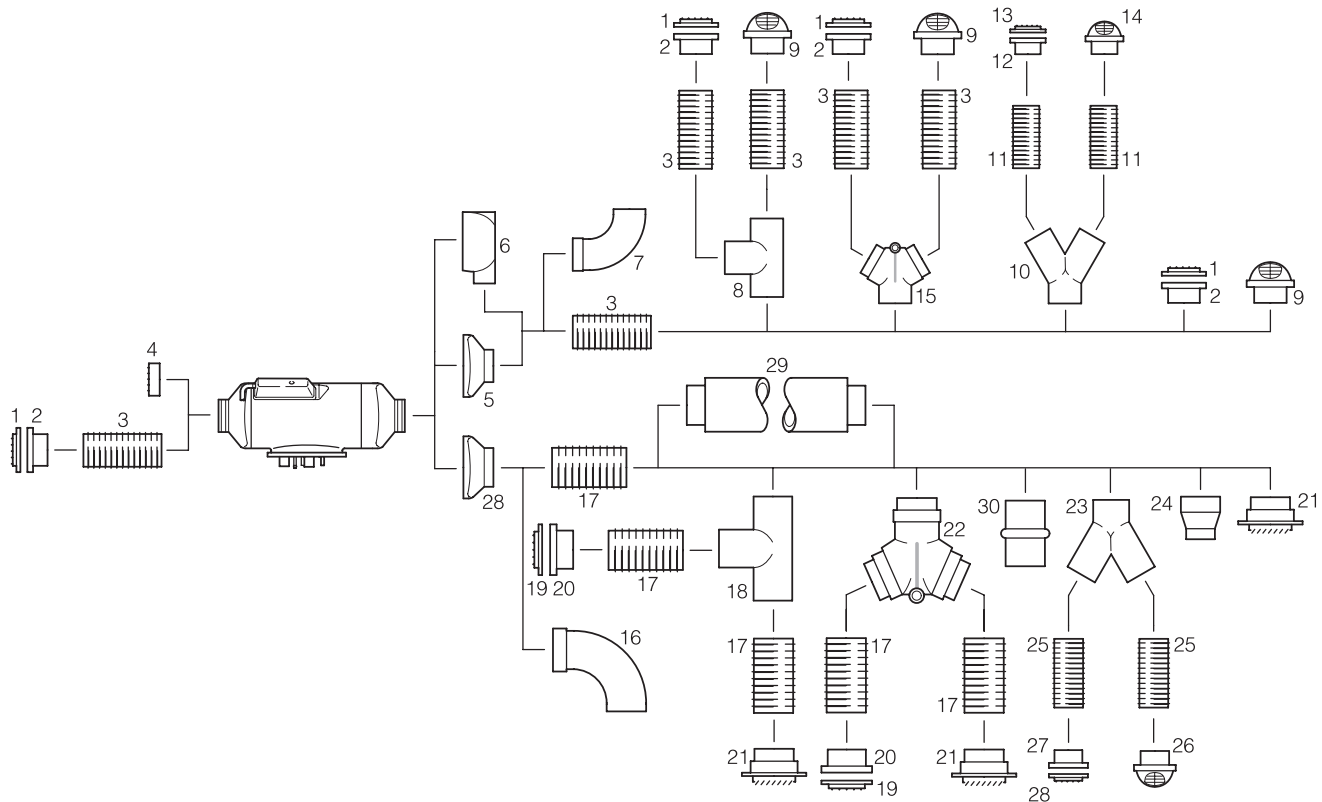

1  
2  
3

## DUCTING RATING GUIDE FOR B1LC COMPACT

Fig. No.	DESIGNATION  (measurements in millimeters)	COMPONENT RATING		See per No. Air Ducting
		1-duct	2-duct	
	Heating air ducting with reduction hood 60 dia. (heater rating 6)			
1	Grille	1.2	0.4	16
2	Connecting socket, plastic	0.3	0	25
3	Flexible pipe, 60 dia. per m	1	0.25	1
-	90 <sup>0</sup> pipe bend of flex. pipe, 60 dia.	0.5	0.1	1
4	Protective grille	0.15	-	18
5	Reduction hood 60 dia.	0	0	31
6	Spherical reduction hood, 60 dia.	1.7	1.7*	32
7	Pipe bend, 60 dia.	3	*	35
8	T-piece, 60 dia.	-	0.3	40
9	Outlet grill (rotatable) 60 dia.	1	0.15	10
10	Y-piece, 60 dia.	-	0.85	44
11	Flexible pipe, 50 dia. per m	-	0.25	1
-	90 <sup>0</sup> pipe bend of flex. pipe, 50 dia.	-	0.1	1
12	Connecting piece	-	0	25
13	Outlet grill	-	0.15	16
14	Outlet grill (rotatable) 50 dia.	-	0.15	10
	Regulating valve 60x60x60 dia. with flap			
15	Position "middle"	-	0	41
	Position "right/left"	-	1	
	Heating air ducting with reduction hood 75 dia. (heater rating 15)			
16	Pipe bend, 75 dia.	2	2*	35
17	Flexible pipe, 75 dia., per m	1	0.25	1
-	90 <sup>0</sup> pipe bend of flex. pipe, 75 dia.	0.7	0.15	1
18	T-piece 75x75x75 dia.	-	0.7	40
19	Grille, 75 dia.	0.3	0	16
20	Connecting socket, metal, 75 dia.	0	0	27
21	Outlet grill (rotatable) 75 dia.	0.7	0.15	11
	Regulating valve 75x75x75 dia. with flap			
22	Position "middle"	-	0	41
	Position "right/left"	-	1	
23	Y-piece 50x75x50 dia.	-	1.3	43
24	Reducing piece, 75 dia. - 50 dia.	-	0.8	47
25	Flexible pipe, 50 dia. per m	-	1	1
-	90 <sup>0</sup> pipe bend of flex. pipe, 50 dia.	-	0.8	1
26	Outlet grill (rotatable) 50 dia.	-	0.35	10
27	Connecting socket, plastic, 50 dia.	-	0	25
28	Reduction hood, 75 dia.	0	0	31
29	Silencer, 75 dia.	1	-	3
30	Connector, 75 dia.	-	-	46

\* Component is in front of the 2-duct system. In the case of a combination of air-ducting parts - dia. 60 at the intake side and dia. 75 at the exhaust side - the rating of the components at the exhaust side must be multiplied by 0.4. The heating rating 6 applies.

## DUCTING RATING GUIDE FOR B3LC *COMPACT*

Heater Rating 6 - applies with a 75mm dia. outlet hood.

Heater Rating 13 - applies with a 90mm dia. outlet hood.

The sketch shows how the most important air ducting parts that can be used. They are not intended as examples of installation.

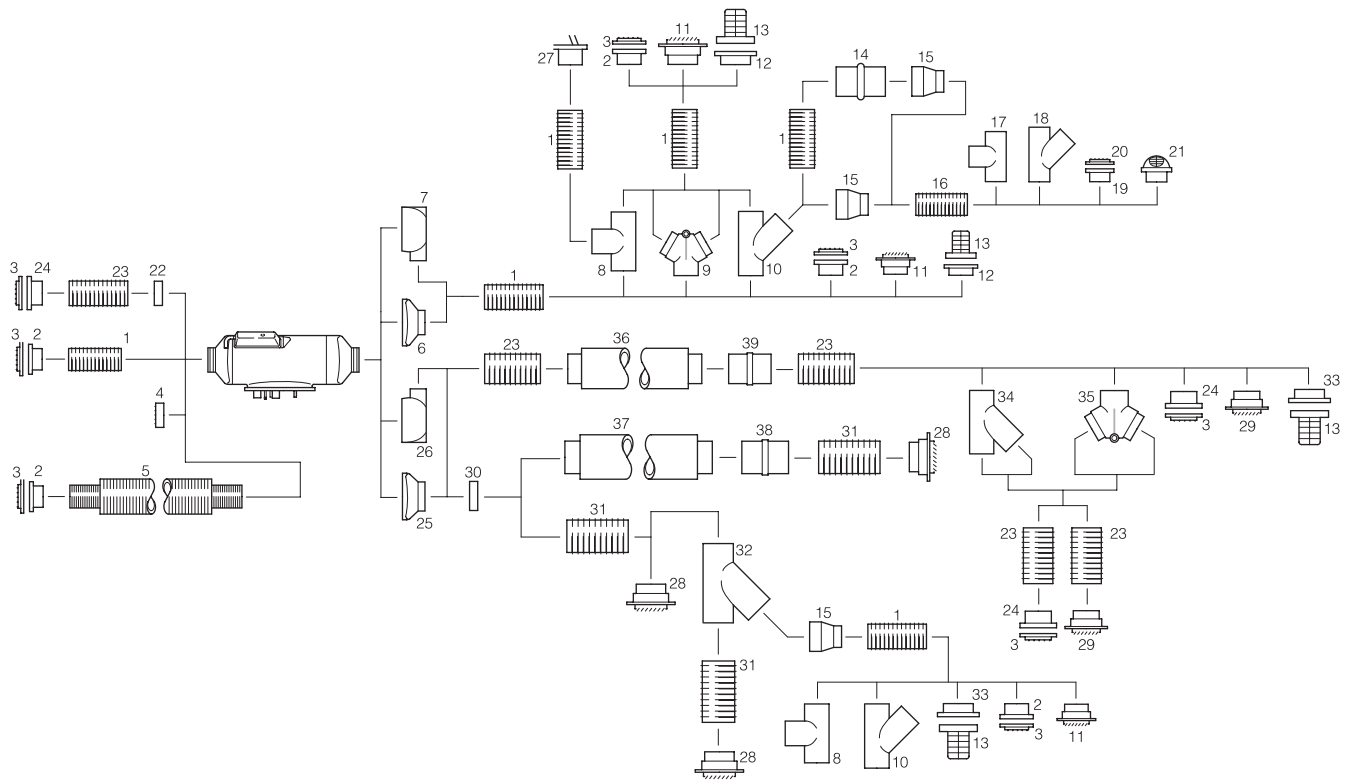

1  
2  
3

## DUCTING RATING GUIDE FOR B3LC COMPACT

Fig. No.	DESIGNATION  (measurements in millimeters)	COMPONENT RATING				See per No. Air Ducting
		1-duct		2-duct		
	Heating air ducting with reduction hood 75 dia. (heater rating 6) Heating air ducting with reduction hood 90 dia. (heater rating 13)	75	90	75	90	
1	Flexible pipe, 75 dia. per m	1	0.9	0.3	0.5	1
2	Connecting socket, metal, 75 dia.	0.3	0.3	0	0	27
3	Grille	0.8	0.5	0.3	0	16
4	Grille, 75 dia.	0.3	0.3	-	-	18
5	Intake Silencer, 75 dia.	0.5	0.5	-	-	4
6	Reduction hood, 75 dia.	0	-	-	-	31
7	Spherical reduction hood, 75 dia.	2.6	-	-	-	32
8	T-piece 75x75x75 dia.	-	-	0.5	0.5	40
9	Regulating valve 75x75x75 dia.	-	-	0.5	-	41
10	Branch piece 75x75x75 dia.	-	-	0.8	0.8	45
11	Outlet grill (rotatable) 75 dia.	0.8	-	0.5	-	11
12	Connector, 75 dia.	0.5	-	0.3	0.3	17.2
13	Outlet grill	0.3	0.3	0.2	0.2	17
14	Connector, 75 dia.	0.3	-	0	-	46
15	Reduction piece, 75 dia. - 60 dia.	-	-	0.3	0	47
16	Flexible pipe, 60 dia. per m	-	-	0.8	-	1
17	T-piece 60x60x60 dia.	-	-	0	-	40
18	Branch piece 60x60x60 dia.	-	-	0	-	45
19	Connecting socket, plastic, 60 dia.	-	-	-	-	25
20	Grille, 60 dia.	-	-	0.2	-	16
21	Outlet grill (rotatable) 60 dia.	-	-	0.8	-	10
22	Ring, 75x90 dia.	0.3	0.3	-	-	36
23	Flexible pipe, 90 dia. per m	-	1	-	-	1
24	Connecting socket, metal, 90 dia.	-	0.5	-	-	27
25	Reduction hood, 90 dia.	-	0	-	-	31
26	Spherical reduction hood, 90 dia.	-	1.4	-	-	32
27	Round outlet, 75 dia.	-	-	-	-	12
28	Outlet grill (rotatable) 100 dia.	-	2.3	-	0	11
29	Outlet grill (rotatable) 90.	-	2.8	-	0	11
30	Grille, round, 90x100 dia.*	-	0	-	-	18
31	Flexible pipe, 100 dia. per m	-	-	-	-	1
32	Y-piece, 100x100x100 dia.	-	-	-	0	45
33	Connector, 90 dia.	-	0.5	-	-	17.2
34	Y-piece	-	-	0.6	0.6	45
35	Regulating valve 90x90x90 dia. with flap Position "middle" Position "right/left"	-	0 1			41
36	Silencer, 90 dia.	-	1	-	-	3
37	Silencer, 100 dia.	-	1	-	-	3
38	Connector, 100 dia.	-	-	-	-	46
39	Connecting socket, 60 dia.	-	-	0.3	-	46

\* Pos. 30 - if used as adapter 90x100 dia., cut out the mesh.

## DUCTING RATING GUIDE FOR AIRTRONIC 5

### Heater Rating 10

The sketch shows how the most important air ducting parts that can be used. They are not intended as examples of installation.

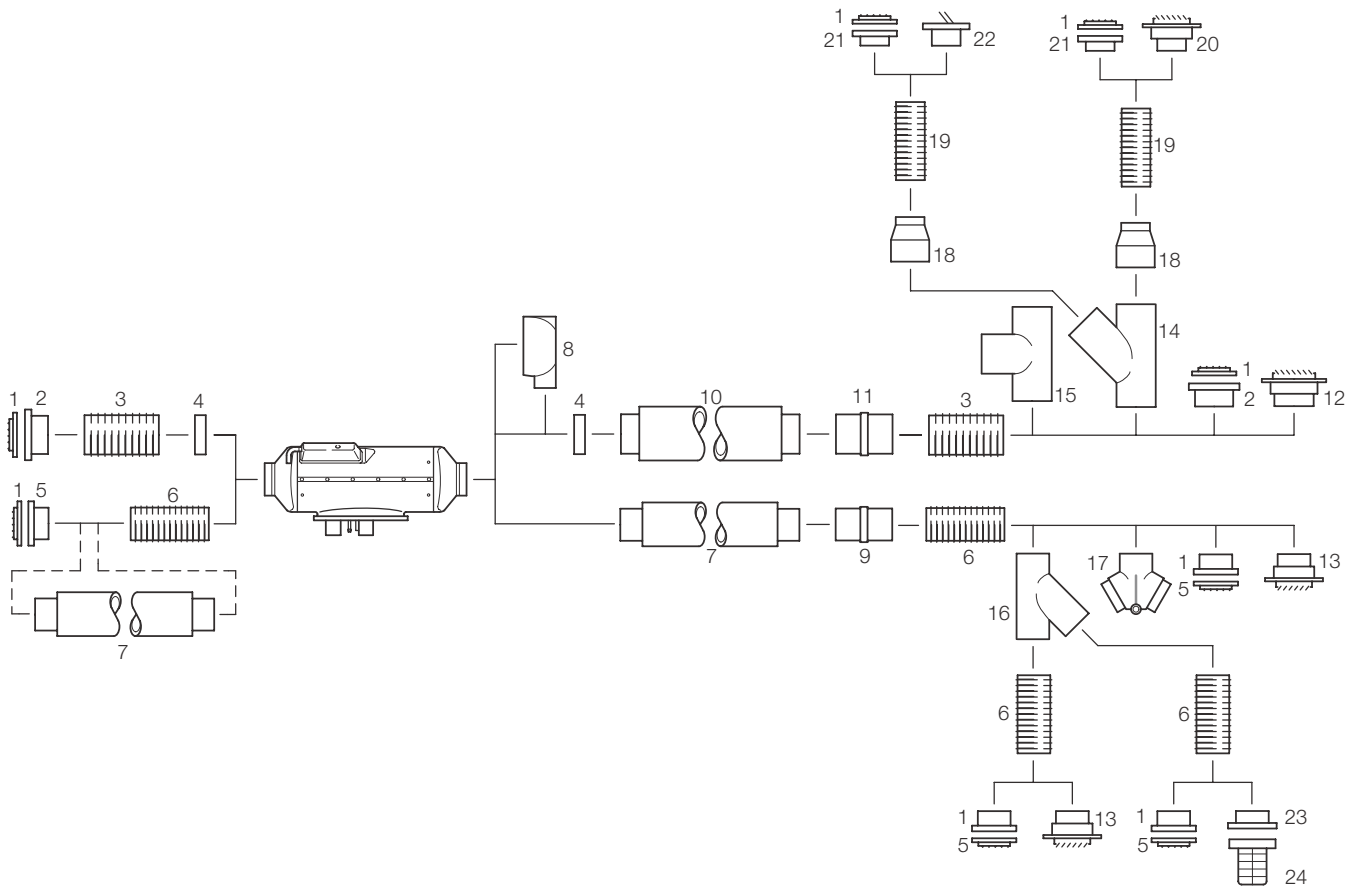

## DUCTING RATING GUIDE FOR AIRTRONIC 5

Fig. No.	DESIGNATION  (measurements in millimeters)	COMPONENT RATING		See per No. Air Ducting
		1-duct	2-duct	
	<b>Heating air ducting with reduction hood 90 dia.</b> (heater rating 10)			
1	Grille	0.5	0.25	16
2	Connecting socket, metal, 100 dia.	0	0	26
3	Flexible pipe, 100 dia. per m	0.5	0.25	1
	Bend, 90° of flexible pipe, 100 dia.	0	0	1
4	Grille, 90x100 dia.*	0	-	18
5	Connector piece, 90 dia.	0	0	27
6	Flexible pipe, 90 dia. per m	1.0	0.3	1
	Bend, 90° of flexible pipe, 90 dia.	0.25	0	1
7	Silencer, 90 dia.	0.6	0.3	3
8	Spherical reduction hood, 90 dia.	1.5	-	31
9	Connector, 90 dia.	-	-	46
10	Silencer, 100 dia.	0.25	0	3
11	Connector, 100 dia.	-	-	46
12	Outlet grill (rotatable) 100 dia.	3.25	1.0	11
13	Outlet grill (rotatable) 90 dia.	3.25	1.0	11
14	Y-piece 100x100x100 dia.	0.5	0	45
15	T-piece 100x100x100 dia.	0.25	0	40
16	Y-piece 90x90x90 dia.	0.5	0	45
	Regulating valve 90x90x90 dia.			
17	Position "middle"	0	-	41
	Position "right/left"	1	-	
18	Reduction piece, 100 dia. - 75 dia.	2.75	1.0	47
	Flexible pipe, 75 dia. per m	-	1.5	1
19	Bend, 90° of flexible pipe, 75 dia.	-	0.5	1
20	Outlet grill (rotatable) 75 dia.	-	1.25	11
21	Connecting socket, metal, 75 dia.	-	0	27
22	Round outlet, 75 dia., closing	-	-	12
23	Connector, 90 dia.	-	-	17.2
24	Outlet grill	-	-	17

\* Pos. 4 - if used as adapter 90 x 100 dia., cut out the mesh.

## DUCTING RATING GUIDE FOR D8LC

### Heater Rating 8

The sketch shows how the most important air ducting parts that can be used. They are not intended as examples of installation.

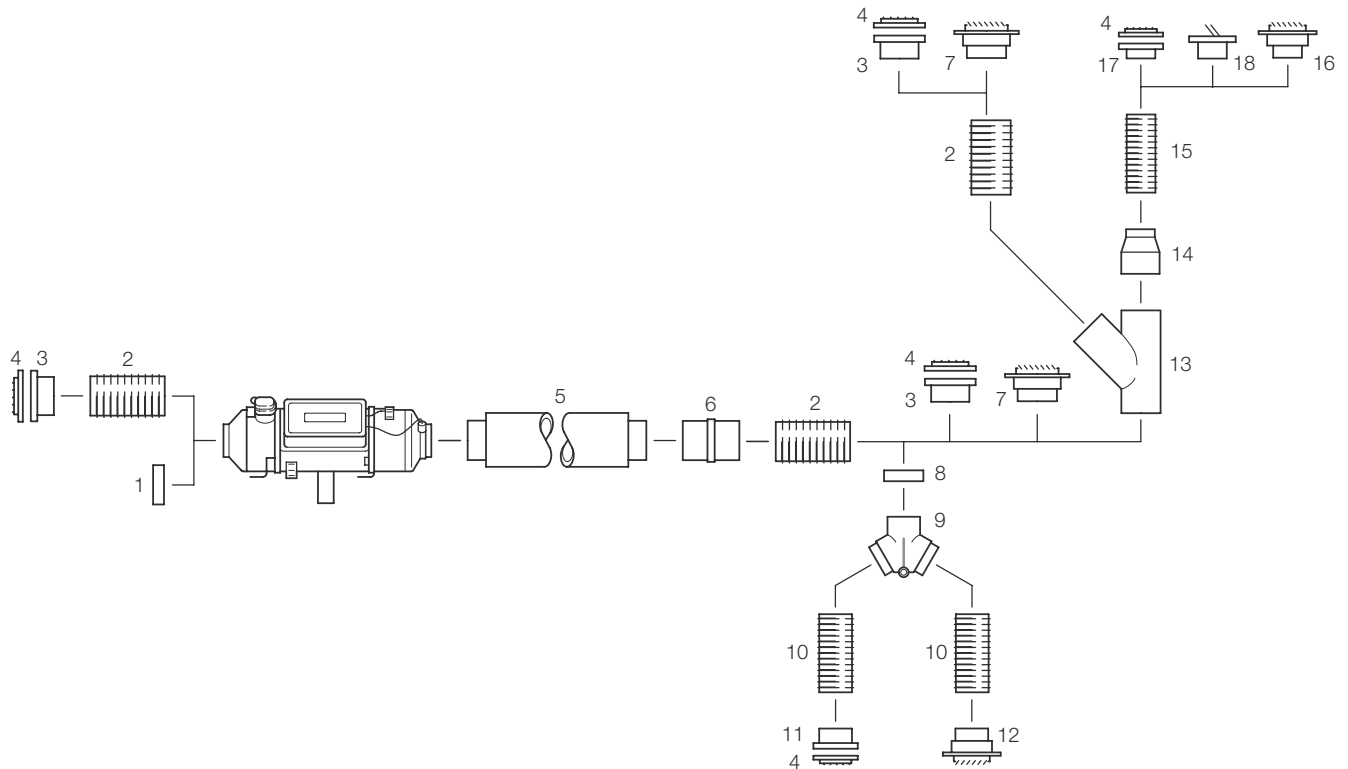

1  
2  
3

## DUCTING RATING GUIDE FOR D8LC

Fig. No.	DESIGNATION  (measurements in millimeters)	COMPONENT RATING		See per No. Air Ducting
		1-duct	2-duct	
	Heating air ducting with reduction hood 100 dia. (heater rating 8)			
1	Grille, 100 dia.	0.1	-	18
2	Flexible pipe, 100 dia., per m	1.0	0.25	1
-	Pipe bend, 90°, of flex. pipe, 100 dia.	0.5	0.15	1
3	Connecting socket, metal, 100 dia.	0.18	0.1	26
4	Grille, painted, 100 dia.	1.8	0.1	16
-	Grille, nickel-plated, 100 dia.	1.8	0.1	16
5	Silencer, 100 dia.	1.1	0.25	3
6	Connector socket, 100 dia.	-	-	46
7	Outlet grill (rotatable), 100 dia.	3.25	1.1	11
8	Grille, 90x100 dia.*	0	-	18
9	Regulating valve 100x100x100 dia.	2.4	-	41
10	Flexible pipe, 90 dia., per m	1.0	0.25	1
11	Connecting socket, metal, 90 dia.	-	-	27
12	Outlet grill (rotatable) 90 dia.	-	1.4	11
13	Y-pipe 100x100x100 dia.	0	-	45
14	Reduction piece, 100 dia. - 74 dia.	-	0.55	51
15	Flexible pipe 75 dia. per m	-	1.1	1
-	Pipe bend, 90° of flex. pipe, 75 dia.	-	1.1	1
16	Outlet grill (rotatable) 75 dia.	-	-	11
17	Connector socket, 75 dia.	-	0.1	27
18	Connecting socket, metal, 75 dia.	-	0.15	12

\*Pos. 8 - if used as adapter 90x100 dia., cut out the mesh.

**Espar Products, Inc.**  
(800) 387-4800  
(905) 670-0960  
(905) 670-0728 Fax  
inquiries@espar.com  
www.espar.com

